

# CY8CPROTO-041TP PSOC™ 4100T Plus CAPSENSE™ Prototyping Kit guide

## About this document

### Scope and purpose

This guide helps you get acquainted with the CY8CPROTO-041TP PSOC™ 4100T Plus CAPSENSE™ Prototyping Kit. It explains the kit's operation, describes the out-of-the-box (OOB) example and its functionality, and provides hardware details of the board.

### Intended audience

This kit is designed for technical specialists who are familiar with the PSOC™ 4 MCU and CAPSENSE™ technology.

**Note:** *Use this kit under laboratory conditions.*

### Reference kit

Product(s) embedded on a PCB with a focus on specific applications and defined use cases that may include software. PCB and auxiliary circuits are optimized for the requirements of the target application.

**Note:** *Boards do not necessarily meet safety, EMI, or quality standards (e.g., UL, CE) requirements.*

## Important notice

**“Evaluation Boards and Reference Boards” shall mean products embedded on a printed circuit board (PCB) for demonstration and/or evaluation purposes, which include, without limitation, demonstration, reference and evaluation boards, kits and design (collectively referred to as “Reference Board”).**

**Environmental conditions have been considered in the design of the Evaluation Boards and Reference Boards provided by Infineon Technologies. The design of the Evaluation Boards and Reference Boards has been tested by Infineon Technologies only as described in this document. The design is not qualified in terms of safety requirements, manufacturing and operation over the entire operating temperature range or lifetime.**

**The Evaluation Boards and Reference Boards provided by Infineon Technologies are subject to functional testing only under typical load conditions. Evaluation Boards and Reference Boards are not subject to the same procedures as regular products regarding returned material analysis (RMA), process change notification (PCN) and product discontinuation (PD).**

**Evaluation Boards and Reference Boards are not commercialized products, and are solely intended for evaluation and testing purposes. In particular, they shall not be used for reliability testing or production. The Evaluation Boards and Reference Boards may therefore not comply with CE or similar standards (including but not limited to the EMC Directive 2004/EC/108 and the EMC Act) and may not fulfill other requirements of the country in which they are operated by the customer. The customer shall ensure that all Evaluation Boards and Reference Boards will be handled in a way which is compliant with the relevant requirements and standards of the country in which they are operated.**

**The Evaluation Boards and Reference Boards as well as the information provided in this document are addressed only to qualified and skilled technical staff, for laboratory usage, and shall be used and managed according to the terms and conditions set forth in this document and in other related documentation supplied with the respective Evaluation Board or Reference Board.**

**It is the responsibility of the customer’s technical departments to evaluate the suitability of the Evaluation Boards and Reference Boards for the intended application, and to evaluate the completeness and correctness of the information provided in this document with respect to such application.**

**The customer is obliged to ensure that the use of the Evaluation Boards and Reference Boards does not cause any harm to persons or third party property.**

**The Evaluation Boards and Reference Boards and any information in this document is provided "as is" and Infineon Technologies disclaims any warranties, express or implied, including but not limited to warranties of non-infringement of third party rights and implied warranties of fitness for any purpose, or for merchantability.**

**Infineon Technologies shall not be responsible for any damages resulting from the use of the Evaluation Boards and Reference Boards and/or from any information provided in this document. The customer is obliged to defend, indemnify and hold Infineon Technologies harmless from and against any claims or damages arising out of or resulting from any use thereof.**

**Infineon Technologies reserves the right to modify this document and/or any information provided herein at any time without further notice.**

### Safety precautions

**Note:** Please note the following warnings regarding the hazards associated with development systems.

**Table 1** Safety precautions

	<p><b>Caution:</b> The evaluation or reference board contains parts and assemblies sensitive to electrostatic discharge (ESD). Electrostatic control precautions are required when installing, testing, servicing or repairing the assembly. Component damage may result if ESD control procedures are not followed. If you are not familiar with electrostatic control procedures, refer to the applicable ESD protection handbooks and guidelines.</p>
---	--

### Table of contents

	<b>About this document</b> .....	1
	<b>Important notice</b> .....	2
	<b>Safety precautions</b> .....	3
	<b>Table of contents</b> .....	4
<b>1</b>	<b>Introduction</b> .....	6
1.1	Kit contents .....	6
1.2	Getting started .....	8
1.3	Additional learning resources .....	9
1.4	Technical support .....	9
<b>2</b>	<b>Kit operation</b> .....	10
2.1	Theory of operation .....	10
2.2	Using the OOB example CE240380 .....	14
2.3	Creating a project and program/debug using ModusToolbox™ .....	18
<b>3</b>	<b>Hardware</b> .....	22
3.1	Schematics .....	22
3.2	Hardware functional description .....	22
3.2.1	PSOC™ 4100T Plus MCU features .....	22
3.2.1.1	PSOC™ 4100T Plus MCU power .....	25
3.2.1.2	PSOC™ 4100T Plus MCU external programming/debugging header .....	29
3.2.1.3	Reset button .....	30
3.2.2	PSOC™ 5LP-based KitProg3 programmer and debugger .....	30
3.2.2.1	KitProg3 onboard target voltage measurement .....	31
3.2.2.2	KitProg3 programming mode selection button and status LED .....	32
3.2.3	Power supply system .....	32
3.2.3.1	Target reference voltage switch .....	35
3.2.4	CAPSENSE™ .....	35
3.2.4.1	Capacitive sensing .....	35
3.2.5	Ambient light sensor .....	38
3.2.6	Crystal .....	39
3.2.7	User LEDs .....	39
3.2.8	User button .....	40
3.2.9	Expansion headers .....	41
3.2.9.1	Multi-Sense expansion connector .....	41
3.2.9.1.1	Power supply .....	41
3.2.9.1.2	Digital interface .....	42
3.2.9.1.3	Sensor interface .....	42
3.2.9.2	I/O expansion headers .....	43
3.3	CY8CPROTO-041TP kit rework for evaluating additional features .....	45

## Table of contents

---

3.3.1	Enabling the external programming/debugging interface to the PSOC™ 4100T Plus device . . .	45
3.3.2	Enabling the external power input for PSOC™ 4100T Plus device . . . . .	47
3.3.3	Enabling 1.8 V supply for the PSOC™ 4100T Plus device . . . . .	47
3.3.4	Enabling the WCO for the PSOC™ 4100T Plus device . . . . .	49
3.3.5	Enabling additional sense signal for Multi-Sense expansion connector . . . . .	50
3.4	Bill of materials . . . . .	51
	<b>Glossary</b> . . . . .	52
	<b>Revision history</b> . . . . .	54
	<b>Trademarks</b> . . . . .	55
	<b>Disclaimer</b> . . . . .	56

## 1 Introduction

### 1 Introduction

Wearable technology devices, from fitness trackers to smart glasses and smart clothes, are becoming increasingly popular. Capacitive sensing is a key feature of any wearable solution. Battery life is a major challenge in wearable technology today. Therefore, there is a constant need to lower power consumption while ensuring the devices remain ON and responsive at all times.

The PSOC™ 4100T Plus series MCU (hereafter called “PSOC™ 4100T Plus”) addresses this challenge by introducing new fifth-generation CAPSENSE™ and multi-sense low-power (MSC-LP) technology. It offers an ultra-low-power touch HMI solution based on integrated "always-on" sensing technology. This enables scanning of low-power buttons, such as power/wakeup buttons, while the device is in deep sleep, and processing the results to wake the device in the event of a touch. This technology has an inherent autonomous scanning capability that does not require CPU intervention for scanning sensors, allowing the device to remain in deep sleep while scanning, thereby reducing overall power consumption.

The CY8CPROTO-041TP PSOC™ 4100T Plus CAPSENSE™ Prototyping Kit allows you to evaluate the features of the PSOC™ 4100T Plus device. The board has the following features:

- A PSOC™ 4100T Plus device
- An onboard programmer/debugger (KitProg3)
- A self-capacitance-based button
- A mutual-capacitance-based button
- A capacitive proximity sensor
- A capacitive touchpad
- An ambient light sensor (ALS)
- User LEDs (PWM enabled)
- A user button

This kit demonstrates the following key capabilities of the fifth-generation low-power CAPSENSE™ technology:

- **Superior touch-sensing performance:**
  - Best-in-class sensitivity, SNR, and immunity to harsh environmental conditions, such as temperature and moisture. To evaluate the SNR performance, follow the steps mentioned in the ‘Monitor data using CAPSENSE™ tuner’ section of the [PSOC™ 4: MSCLP low-power CSD button](#) code example’s README
- **Ultra-low-power capability based on "always-on" sensing:**
  - Ability to obtain power numbers as low as 5 µA in the Wake-On-Touch mode and 96 µA in Active mode (see [CE238886](#) for the scan conditions for achieving this), making it ideal for battery-operated wearable devices

The current sensor tuning is designed to tolerate water droplets, enabling effective operation even when exposed to them.

See [AN85951 - PSOC™ 4 and PSOC™ 6 MCU CAPSENSE™ design guide](#) for details on the features of the fifth-generation low-power CAPSENSE™ - MSC-LP.

Use ModusToolbox™ software to develop and debug your PSOC™ 4 projects. [ModusToolbox™ software](#) is a set of tools that enables you to integrate Infineon devices into your existing development methodology.

If you are new to PSOC™ 4 and ModusToolbox™ software IDE, see [AN79953 - Getting started with PSOC™ 4 MCU](#) for the basics of creating your own designs with the PSOC™ 4 MCU.

#### 1.1 Kit contents

The CY8CPROTO-041TP PSOC™ 4100T Plus CAPSENSE™ Prototyping Kit contains the following:

- PSOC™ 4100T Plus CAPSENSE™ Prototyping Board
- Quick start guide (part of packaging)
- 3 mm add-on overlay (for touchpad wing)

## 1 Introduction

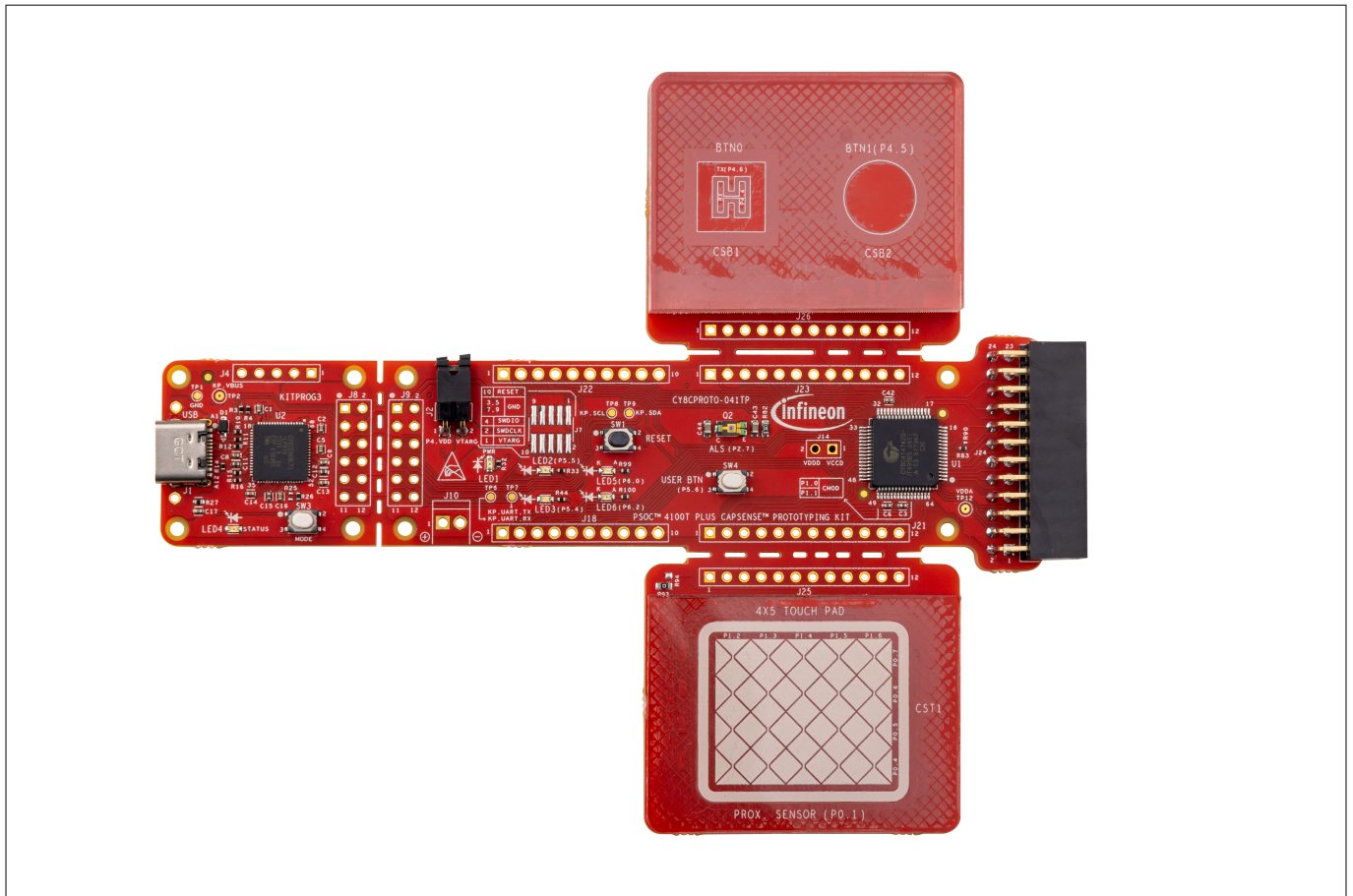

**Figure 1** CY8CPROTO-041TP PSOC™ 4100T Plus CAPSENSE™ Prototyping Board

## 1 Introduction

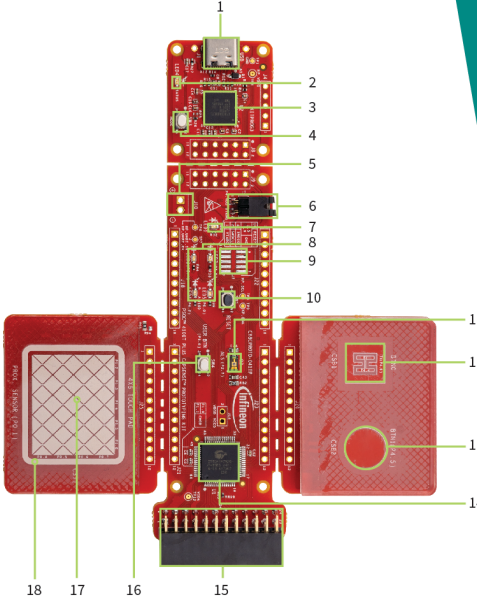

**QUICK START GUIDE**

**PSOC™ 4100T Plus CAPSENSE™ Prototyping Kit  
CY8CPROTO-041TP**

Easy, out-of-the-box experience with 5th-generation CAPSENSE™ technology demonstrating best-in-class low-power touch performance on PSOC™ 4 MCU

**Step 1: Power up the kit**

- Ensure that the jumper is populated at header (J2).
- Connect the board to your PC using the USB-C cable at USB-C connector (J1) and observe that the power and status LEDs (LED1, LED4) turn on.



**Step 2: Test the operation**

- Touch one of the capacitive buttons (either CSB1 or CSB2) and observe that the LED2 (red) or LED3 (green) turns on respectively.
- Swipe on the touchpad (CST1) and observe that the brightness of LED2 (red) and LED3 (green) changes corresponding to finger position on the touchpad.
- Hover your hand over the capacitive proximity sensor (CSP1) and ensure that the brightness of LED5 (blue) changes with proximity.
- Ambient light sensor (ALS) detects changes in illuminance and adjusts the brightness of LED6 (amber) accordingly.

<ol style="list-style-type: none"> <li>1 USB Type-C connector (J1)</li> <li>2 KitProg3 status LED (LED4)</li> <li>3 PSOC™ 5LP MCU with KitProg3 firmware (CY8C5868LTI-LP039 – U2)</li> <li>4 KitProg3 mode switch (SW3)</li> <li>5 External power input (J10)*</li> <li>6 Target MCU current measurement header (J2)</li> <li>7 Power LED (LED1)</li> <li>8 User LED's (LED2, LED3, LED5, LED6)</li> </ol>	<ol style="list-style-type: none"> <li>9 MiniProg4 SWD interface header provision (J7)*</li> <li>10 Reset switch (SW1)</li> <li>11 Ambient light sensor (Q2)</li> <li>12 CSX CAPSENSE™ button (CSB1)</li> <li>13 CSD CAPSENSE™ button (CSB2)</li> <li>14 PSOC™ 4100T Plus MCU (CY8C4147AZQ-T495 – U1)</li> <li>15 Multi-Sense expansion connector (J24)</li> <li>16 User button (SW4)</li> <li>17 CAPSENSE™ touchpad (CST1)</li> <li>18 CAPSENSE™ proximity sensor (CSP1)</li> </ol>
--	--

Note : \*footprint only, not populated on the board

For more information, please visit:  
[www.infineon.com/CY8CPROTO-041TP](http://www.infineon.com/CY8CPROTO-041TP)

Published by Infineon Technologies AG 81726 Munich, Germany

© 2024 Infineon Technologies AG. All Rights Reserved.

Document Number: 002-40374 Rev. \*A  
Date: 12/2024

**Figure 2** CY8CPROTO-041TP PSOC™ 4100T Plus CAPSENSE™ Prototyping Kit quick start guide

Inspect the kit's contents; if you find any part missing, visit the [Infineon Support](#) page for assistance.

To evaluate touchpad operation with a 4 mm overlay, mount the supplied 3 mm add-on overlay on top of the 1 mm overlay on the touchpad wing. For more information, see [CE240556: PSOC™ 4: MSCLP low power self-capacitance touchpad with 4 mm overlay](#).

### 1.2 Getting started

This guide helps you get acquainted with the PSOC™ 4100T Plus CAPSENSE™ Prototyping Kit.

- See the [Kit operation](#) section for an overview of the PSOC™ 4100T Plus device features. Follow the [Using the OOB example CE240380](#) section to quickly review the OOB project preprogrammed in this kit. It also provides steps to create a project and program/debug using ModusToolbox™
- See the [Hardware](#) section for a detailed hardware description, kit schematics, rework instructions, and the bill of materials (BOM)
- Use ModusToolbox™ for application development with the PSOC™ 4100T Plus CAPSENSE™ Prototyping Kit. For the latest software support for this development kit, see the [kit webpage](#)

## 1 Introduction

- ModusToolbox™ software is a free development ecosystem that includes the Eclipse IDE for ModusToolbox™. Using ModusToolbox™, you can enable and configure device resources, and middleware libraries, and program and debug the device. The software can be downloaded from the [ModusToolbox™ software home page](#). For additional information, see the [ModusToolbox™ software user guide](#)
- See the wide range of code examples to evaluate the PSOC™ 4100T Plus CAPSENSE™ Prototyping Kit. These examples help you familiarize yourself with the PSOC™ 4100T Plus device and create the design. You can also find code examples on the GitHub page dedicated to [ModusToolbox™ software-based examples](#)
- To access code examples through ModusToolbox™, see the “Software development for PSOC™ 4” section in [AN79953 - Getting started with PSOC™ 4 MCU](#) under “PSOC™ 4 software resources”

### 1.3 Additional learning resources

Infineon provides a wealth of data on the [PSOC™ 4 product webpage](#) to help you select the suitable PSOC™ device for your design and quickly and effectively integrate the device into your design.

### 1.4 Technical support

For assistance, visit [Infineon Support](#) or the [Infineon Developer Community](#) to post your questions.

You can also use the following support resources if you need quick assistance:

- [Self-help \(Technical documents\)](#)
- [Local sales office locations](#)

2 Kit operation

2 Kit operation

This chapter provides an overview of the features of the PSOC™ 4100T Plus device and a quick overview of the OOB project preprogrammed in this kit. It also provides the steps to create a project and program/debug using ModusToolbox™.

2.1 Theory of operation

The PSOC™ 4100T Plus CAPSENSE™ Prototyping Kit is built around the PSOC™ 4100T Plus device. Figure 3 shows the block diagram of the PSOC™ 4100T Plus device used on the board. For detailed device features, see the device datasheet.

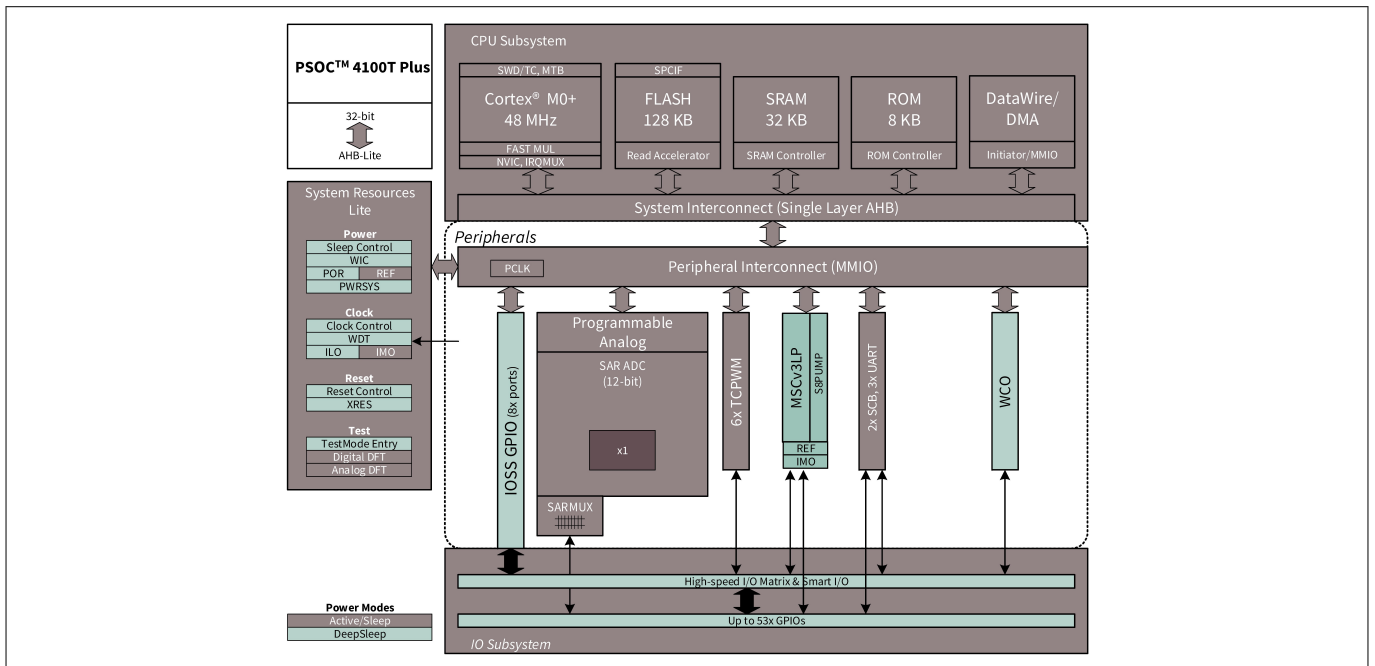
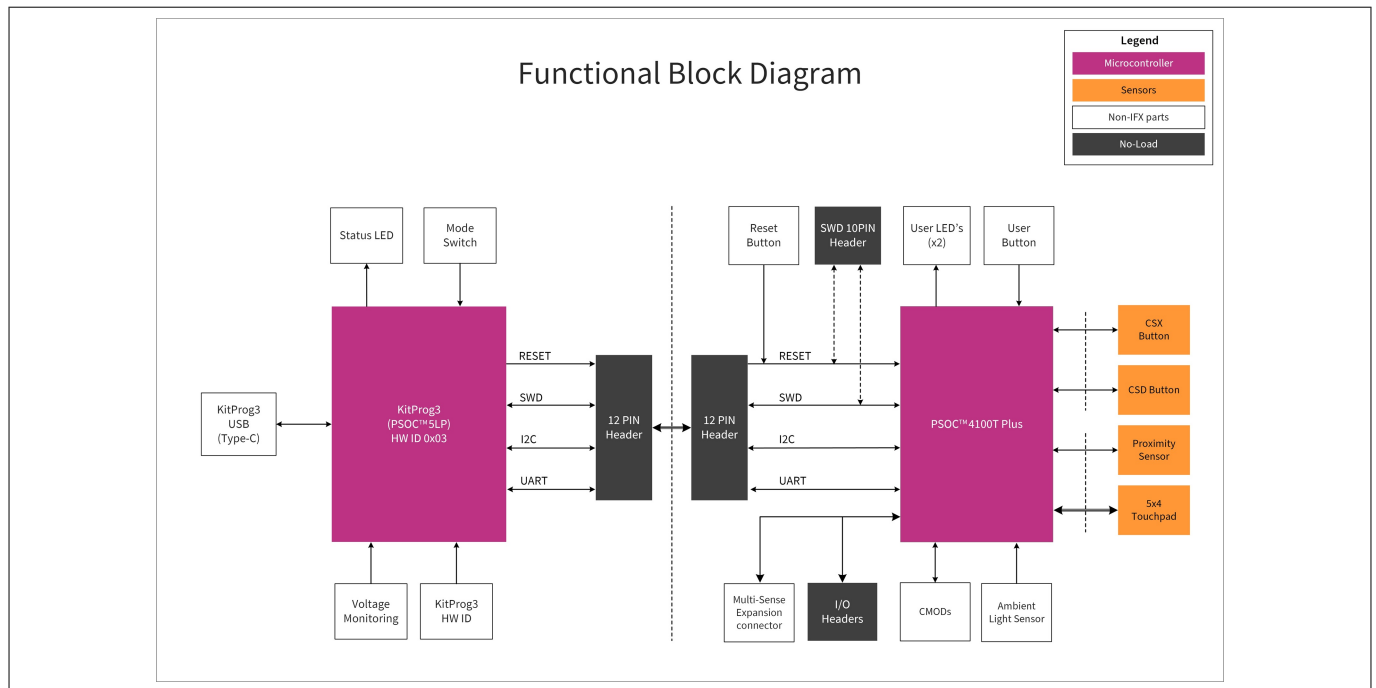

Figure 3 PSOC™ 4100T Plus device block diagram

Figure 4 shows the functional block diagram of the PSOC™ 4100T Plus CAPSENSE™ Prototyping Board.

## 2 Kit operation



**Figure 4 Functional block diagram of CY8CPROTO-041TP PSOC™ 4100T Plus CAPSENSE™ Prototyping Board**

2 Kit operation

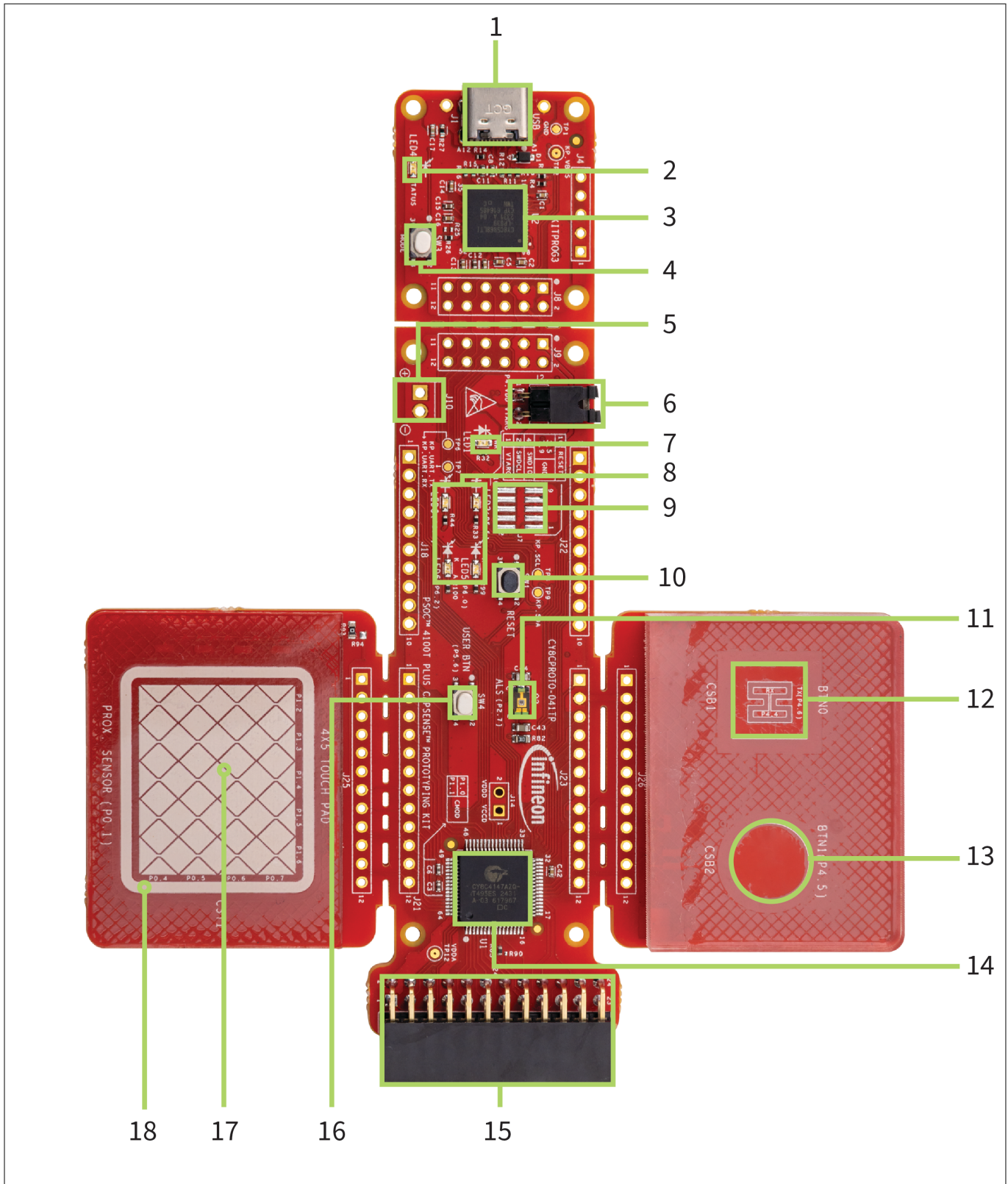

**Figure 5 PSOC™ 4100T Plus CAPSENSE™ Prototyping Board top view**

The PSOC™ 4100T Plus CAPSENSE™ Prototyping Kit demonstrates the capabilities of fifth-generation CAPSENSE™ technology, including low-power operation with always-on sensing and improved touch-sensing performance with CAPSENSE™ widgets using the PSOC™ 4100T Plus device. This board features the following peripherals:

## 2 Kit operation

**Table 2** Peripheral details

Sl. No.	Peripheral	Description
1	KitProg3 Type-C USB connector (J1)	Connect to a PC to use the KitProg3 onboard programmer and debugger, and to provide power to the board.
2	KitProg3 status LED (LED4)	The amber LED4 indicates the status of the KitProg3. For more details on the KitProg3 status, see the <a href="#">KitProg3 user guide</a> .
3	KitProg3 (PSOC™ 5LP) programmer and debugger (CY8C5868LTI-LP039, U2)	The PSOC™ 5LP device (CY8C5868LTI-LP039), serving as KitProg3, is a multifunctional system that includes an SWD programmer, debugger, USB-I <sup>2</sup> C bridge, and USB-UART bridge. For more details, see the <a href="#">KitProg3 user guide</a> .
4	KitProg3 programming mode selection button (SW3)	Use this button to switch between various modes of operation of KitProg3. Note that this board supports only CMSIS-DAP BULK mode. For more details, see the <a href="#">KitProg3 user guide</a> . The function of this button is reserved for future use.
5	External power supply input provision (J10)	Populating J10 enables the connection of an external DC power supply input to the PSOC™ 4100T Plus device.
6	Target MCU current measurement header (J2)	Connect an ammeter to this jumper to measure the current consumed by the PSOC™ 4100T Plus device.
7	Power LED (LED1)	The amber LED indicates the status of the power supplied to the board.
8	User LEDs (LED2, LED3, LED5, LED6)	The user LEDs can operate over the entire voltage range of the PSOC™ 4100T Plus device as they are driven by a MOSFET connected to the USB supply. The LEDs are active HIGH, so the pins must be driven to VDDD to turn on the LEDs.
9	PSOC™ 4100T Plus MCU 10-pin SWD program and debug header provision (J7)	Populating this 10-pin header allows you to program and debug the PSOC™ 4100T Plus MCU using an external programmer, such as MiniProg4.
10	PSOC™ 4100T Plus MCU Reset switch (SW1)	This switch resets the PSOC™ 4100T Plus MCU by connecting the PSOC™ 4100T Plus MCU reset (XRES) pin to ground.
11	ALS Sensor (Q2)	The ambient light sensor (ALS) allows you to evaluate the ADC peripheral of the PSOC™ 4100T Plus MCU.
12	CSX CAPSENSE™ button (CSB1)	The CAPSENSE™ touch-sensing button, capable of both self-capacitance (CSD) and mutual-capacitance (CSX) operation, allows you to evaluate Infineon's fifth-generation CAPSENSE™ technology. This button features a 4 mm acrylic overlay for smooth touch sensing.
13	CSD CAPSENSE™ button (CSB2)	The CAPSENSE™ touch-sensing button, capable of both self-capacitance (CSD) and mutual-capacitance (CSX) operation, allows you to evaluate Infineon's fifth-generation CAPSENSE™ technology. This button features a 4 mm acrylic overlay for smooth touch sensing.
14	PSOC™ 4100T Plus MCU (U1)	This kit highlights the features of the PSOC™ 4100T Plus device and is designed for the 64-pin TQFP part with a 128 KB flash capacity.

(table continues...)

## 2 Kit operation

**Table 2** (continued) Peripheral details

Sl. No.	Peripheral	Description
15	Multi-Sense expansion connector (J24)	The expansion header supports additional CAPSENSE™ pins and Multi-Sense expansion boards.
16	User button (SW4)	Provides an input to the PSOC™ 4100T Plus MCU. Note that when pressed, the button connects the PSOC™ 4100T Plus MCU pin to ground through a current-limiting resistor. Therefore, you need to configure the PSOC™ 4100T Plus MCU pin as a digital input with a resistive pull-up to detect the button press.
17	CSD CAPSENSE™ Touchpad (CST1)	The CAPSENSE™ touch-sensing touchpad, capable of both self-capacitance (CSD) and mutual-capacitance (CSX) operation, allows you to evaluate Infineon's fifth-generation CAPSENSE™ technology. This touchpad features a 1 mm acrylic overlay for smooth touch sensing.
18	CSD CAPSENSE™ Proximity sensor (CSP1)	The CAPSENSE™ touch-sensing proximity, capable of both self-capacitance (CSD) and mutual-capacitance (CSX) operation, allows you to evaluate Infineon's fifth-generation CAPSENSE™ technology. This proximity features a 1 mm acrylic overlay for smooth touch sensing.

See the [Hardware functional description](#) section for details on various hardware blocks.

### 2.2 Using the OOB example CE240380

The PSOC™ 4100T Plus CAPSENSE™ Prototyping Kit is preprogrammed with the [CE240380 – PSOC™ 4: CY8CPROTO-041TP demo](#) code example. This code example demonstrates the key features of the fifth-generation low-power CAPSENSE™ technology in PSOC™ 4100T Plus, including:

- Self-capacitance (self-cap) button, mutual-capacitance (mutual-cap) button, self-cap proximity, and CSD touchpad operation with superior touch sensing performance
- Low-power wake-on-touch approach using a ganged sensor, optimizing power consumption for battery-powered devices

For a detailed description of the project, see the example's [README](#) file in the GitHub repository or in the application's top-level directory when the example is created using ModusToolbox™.

**Note:** *If you ever overwrite the OOB example, you can restore it by programming the PSOC™ 4: CY8CPROTO-041TP demo code example again. For further details, see the section [Creating a project and program/debug using ModusToolbox™](#) for programming the board.*

1. Connect the board to the PC using a USB cable through the KitProg3 USB connector, as shown in [Figure 6](#)

## 2 Kit operation

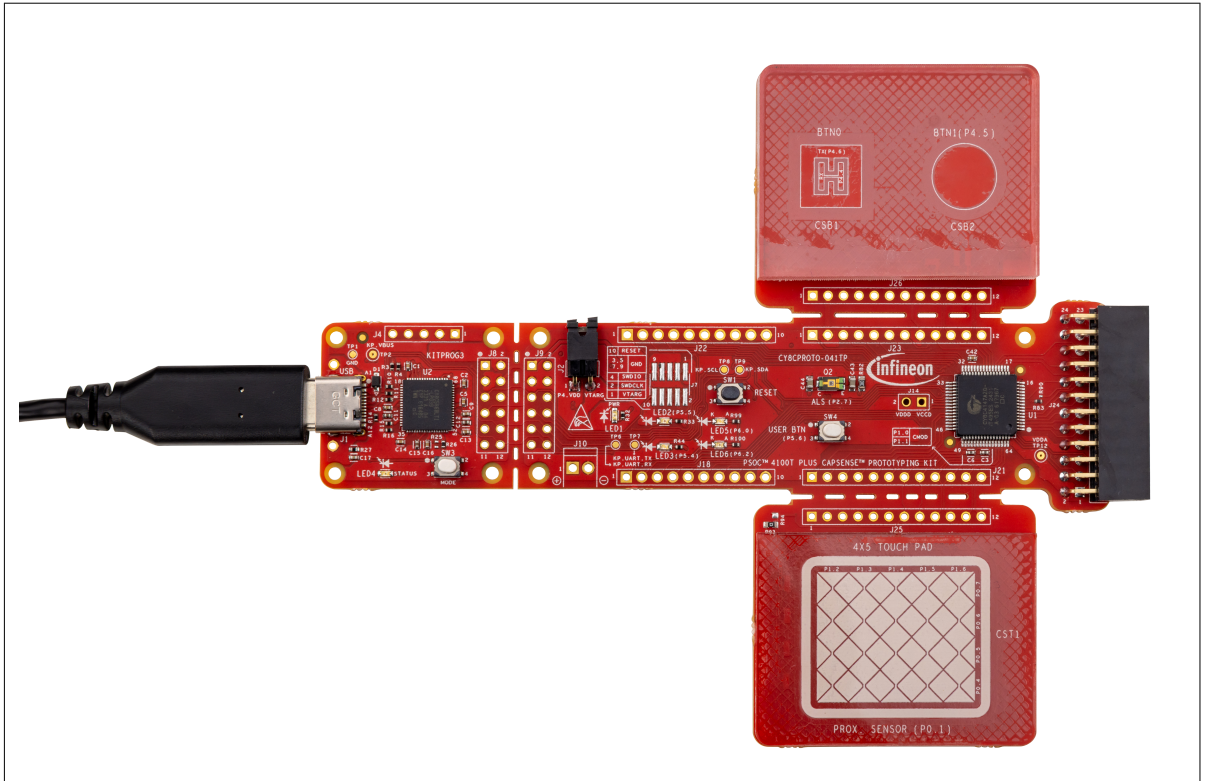

**Figure 6** Connect the USB cable to the USB connector on the board

2. Touch the self-capacitance-based button (CSB2) and observe that LED3 (green) turns on, as shown in [Figure 7](#). Touch the mutual-capacitance-based button (CSB1) with your finger and observe that LED2 (red) turns on, as shown in [CAPSENSE™ CSX button operation with LED indication](#)

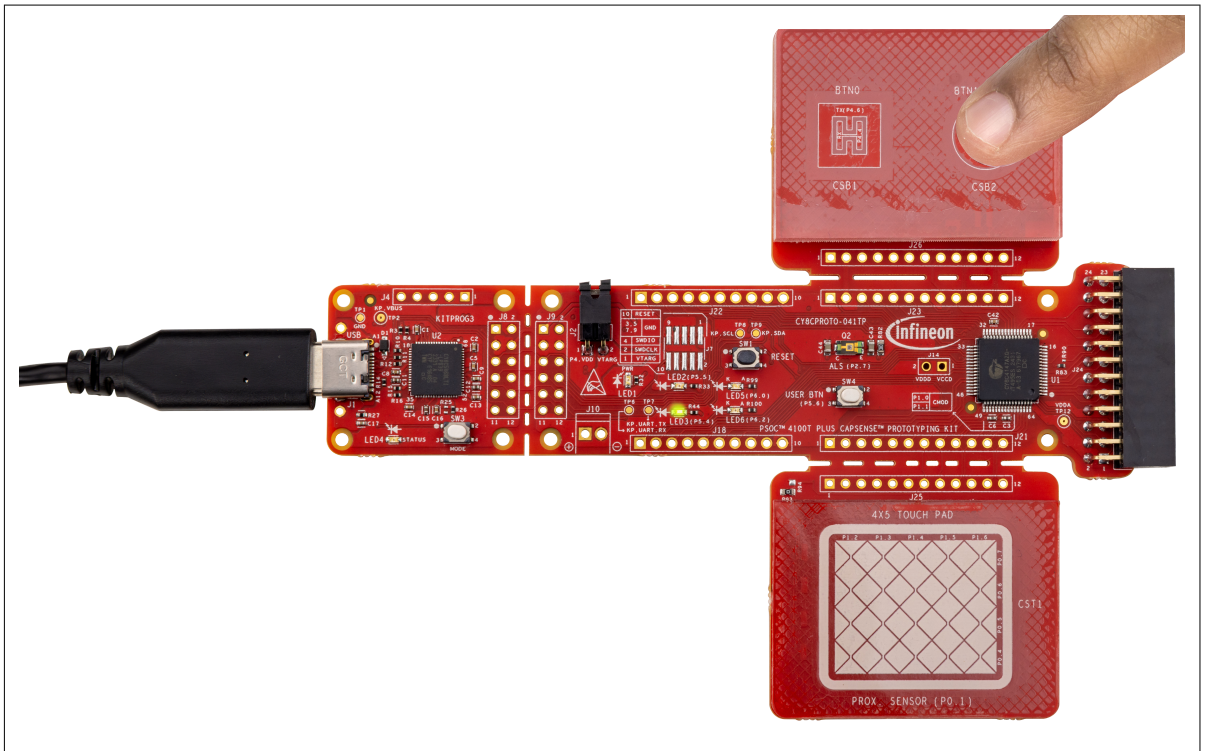

**Figure 7** CAPSENSE™ CSD button operation with LED indication

## 2 Kit operation

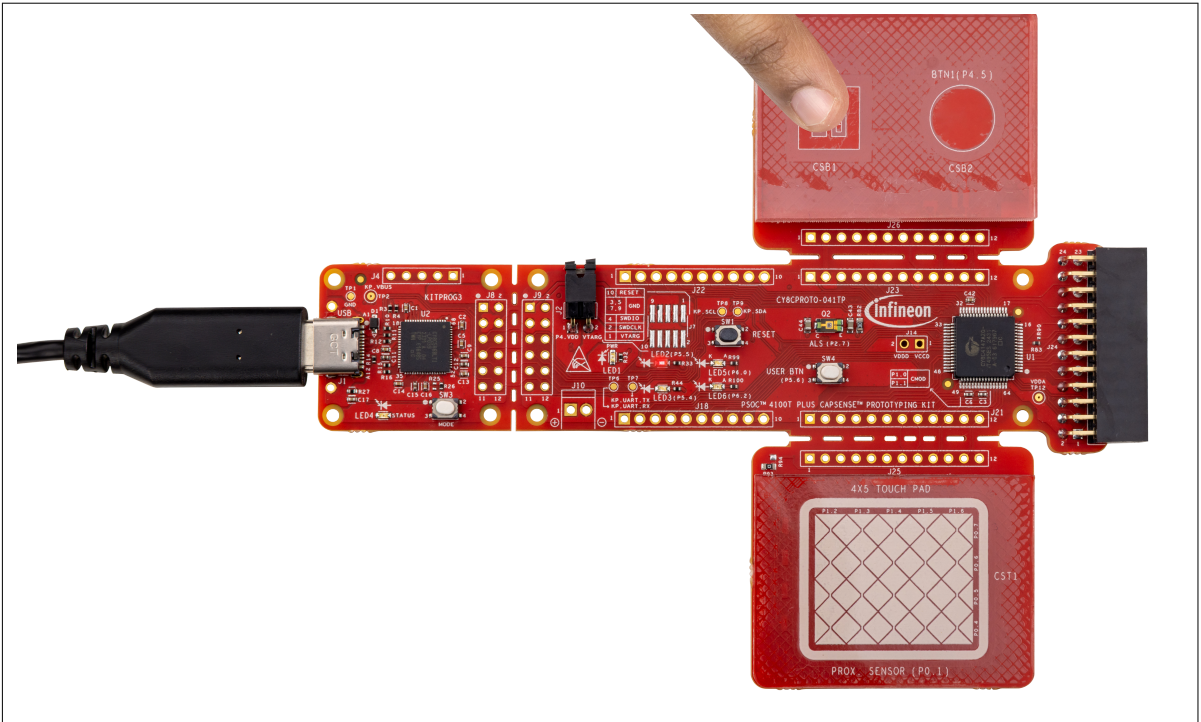

**Figure 8 CAPSENSE™ CSX button operation with LED indication**

3. Touch the touchpad with your finger and observe that LED2 (red) and LED3 (green) turn on, as shown in [Figure 9](#). The brightness of the LEDs will vary based on the touch position. Move your finger along the touchpad to observe this variation

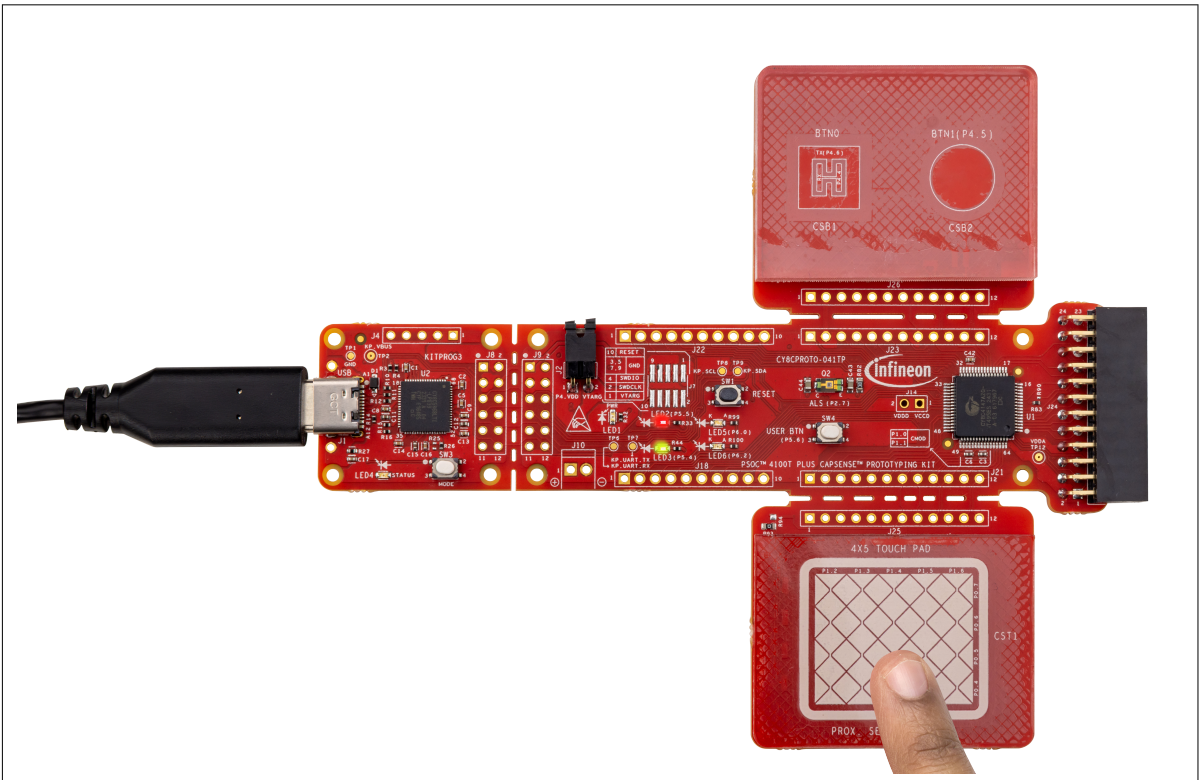

**Figure 9 Capacitive touchpad operation with LED indication**

4. Hover your hand over the capacitive proximity sensor and observe that the brightness of LED5 (blue) changes with the proximity, as shown in [Figure 10](#)

## 2 Kit operation

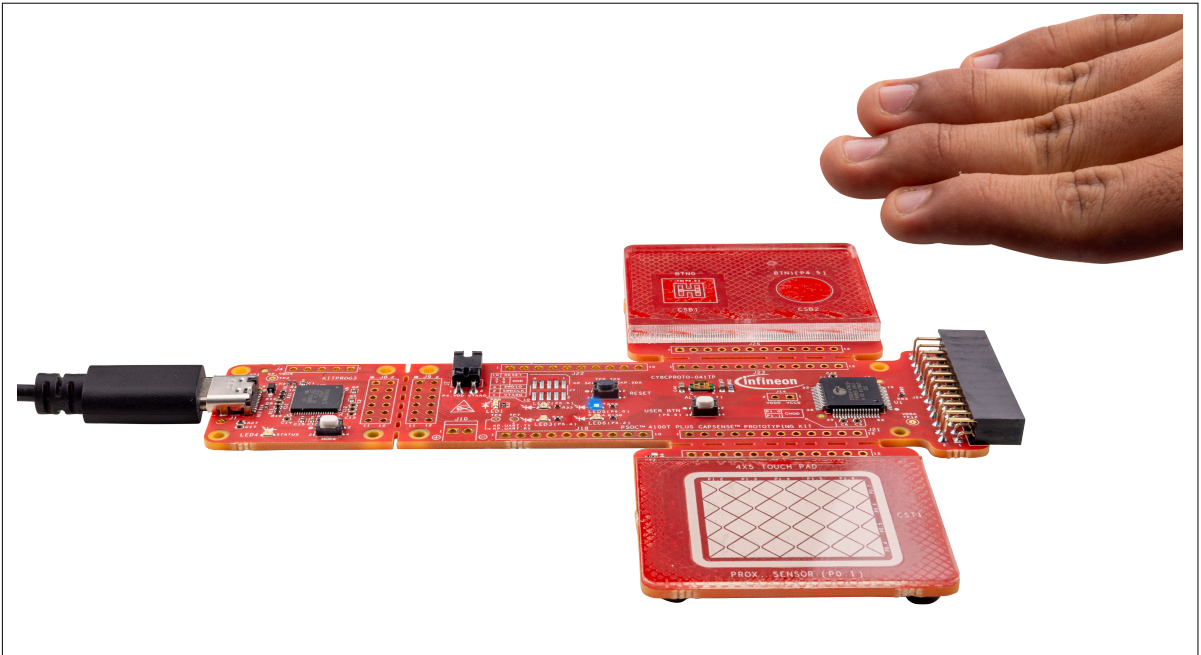

**Figure 10** Capacitive proximity operation with LED indication

5. Hover your hand over the ambient light sensor (ALS) to change the light intensity falling on the ALS. Observe that the brightness of LED6 (amber) changes with the light intensity, as shown in [Ambient Light Sensor \(ALS\) operation with LED indication](#)

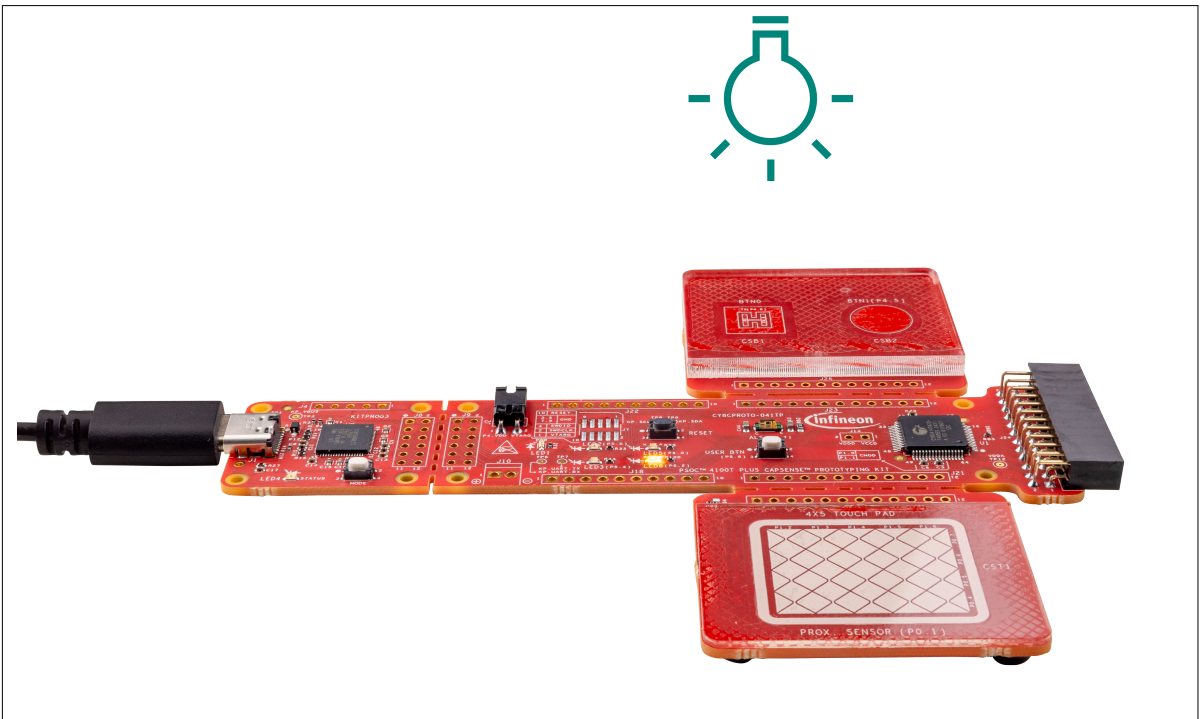

**Figure 11** Ambient light sensor (ALS) operation with LED indication

6. Evaluate the low-power performance by measuring the current values in active, active low refresh rate, and wake-on-touch modes. See the "Measure current at different application states" section of the code example's README for detailed instructions

## 2 Kit operation

**Note:** More code examples are available in the Eclipse IDE for the ModusToolbox™ software (see Figure 15) or on the GitHub page dedicated to ModusToolbox™ software-based examples. These examples can be used to evaluate the board. Some of these examples include:

- PSOC™ 4: MSCLP low-power CSD button
- PSOC™ 4: MSCLP low-power CSX button
- PSOC™ 4: MSCLP low-power CSD touchpad
- PSOC™ 4: MSCLP low-power proximity

### 2.3 Creating a project and program/debug using ModusToolbox™

This section briefly introduces project creation, programming, and debugging using ModusToolbox™. For detailed instructions, see **Help > ModusToolbox™ General Documentation > ModusToolbox™ user guide**.

1. Connect the board to the PC using the USB cable through the KitProg3 USB connector (J1). The kit enumerates as a USB composite device if you are connecting it to the PC for the first time. KitProg3 operates in CMSIS-DAP Bulk mode, and the status LED4 (amber) is always on in CMSIS-DAP Bulk mode. If you do not see the correct LED status, see the [KitProg3 user guide](#) for details on the KitProg3 status and troubleshooting instructions. For updating the KitProg3 firmware, see the "Updating KitProg3" section in the [KitProg3 user guide](#). For commands, see the [Firmware Loader user guide](#).

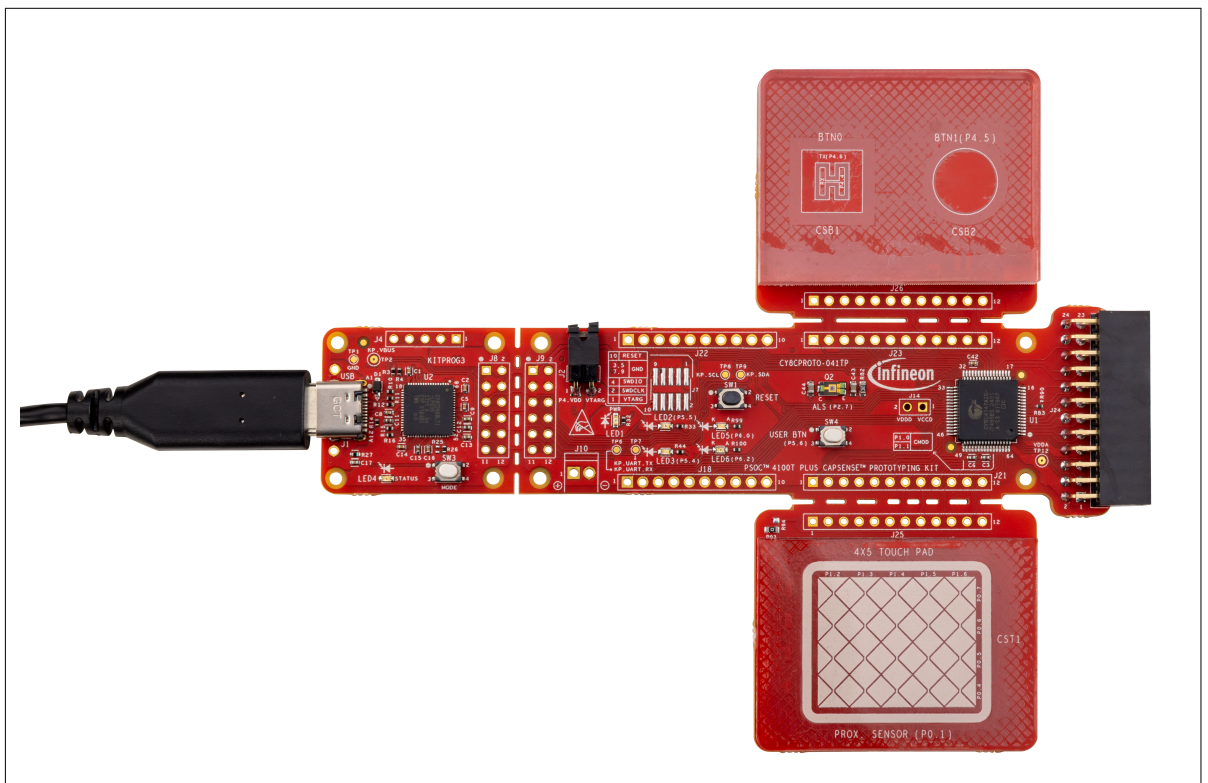

**Figure 12** Connect the USB cable to the USB connector on the board

2. Import the required code example (application) into a new workspace in the Eclipse IDE for ModusToolbox™
  - a. In the **Quick Panel**, click **New Application**

2 Kit operation

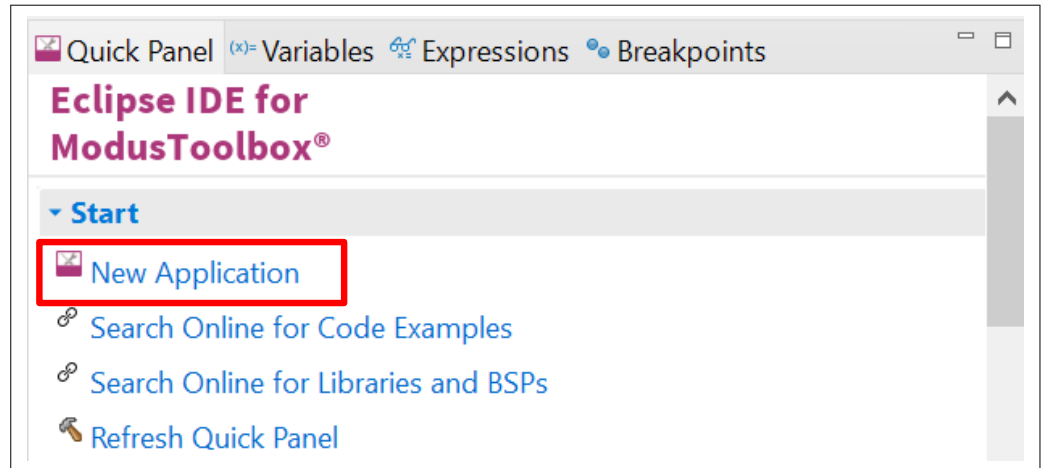

Figure 13 New Application in the Quick Panel

- b. In the **Choose Board Support Package (BSP) - Project Creator** window, follow these steps:
1. Expand the list to show all available PSOC™ 4 BSPs
  2. Select **CY8CPROTO-041TP**, and click **Next**, as shown in Figure 14

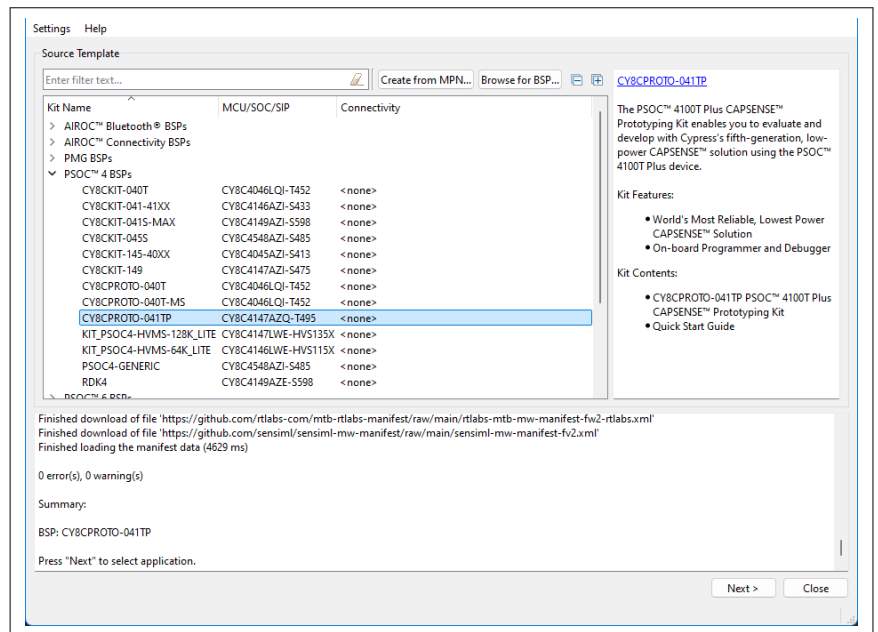
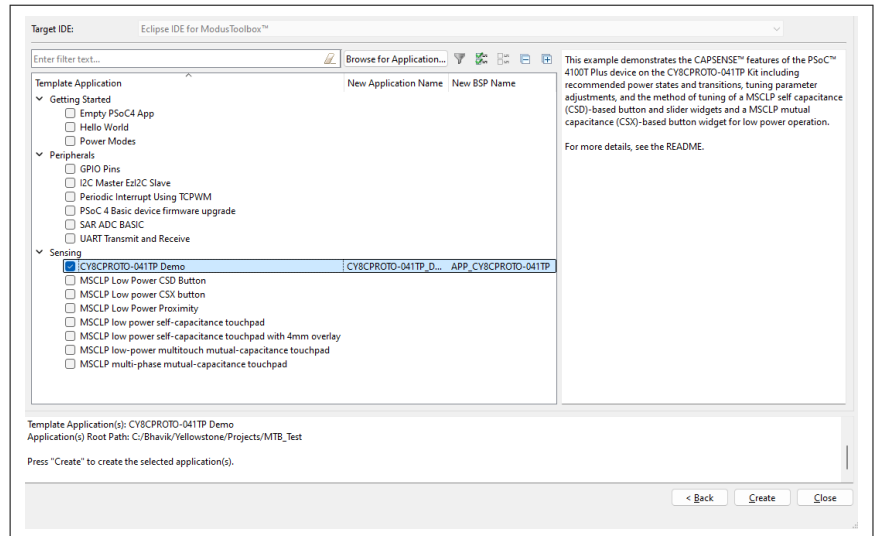

Figure 14 Creating a new application: Choose Board Support Package

3. Select the required application and click **Create**, as shown in Figure 15. The right pane will display the code example description and provide a link to view the README file on GitHub

## 2 Kit operation



**Figure 15** Creating a new application: Select Application

3. In the **Project Explorer** tab, select the **<App\_Name>** project to build and program the PSOC™ 4100T Plus device application
4. In the **Quick Panel** tab, navigate to the **Launches** section, and click the **<App\_Name> Program (KitProg3\_MiniProg4)** configuration, as shown in [Figure 16](#)

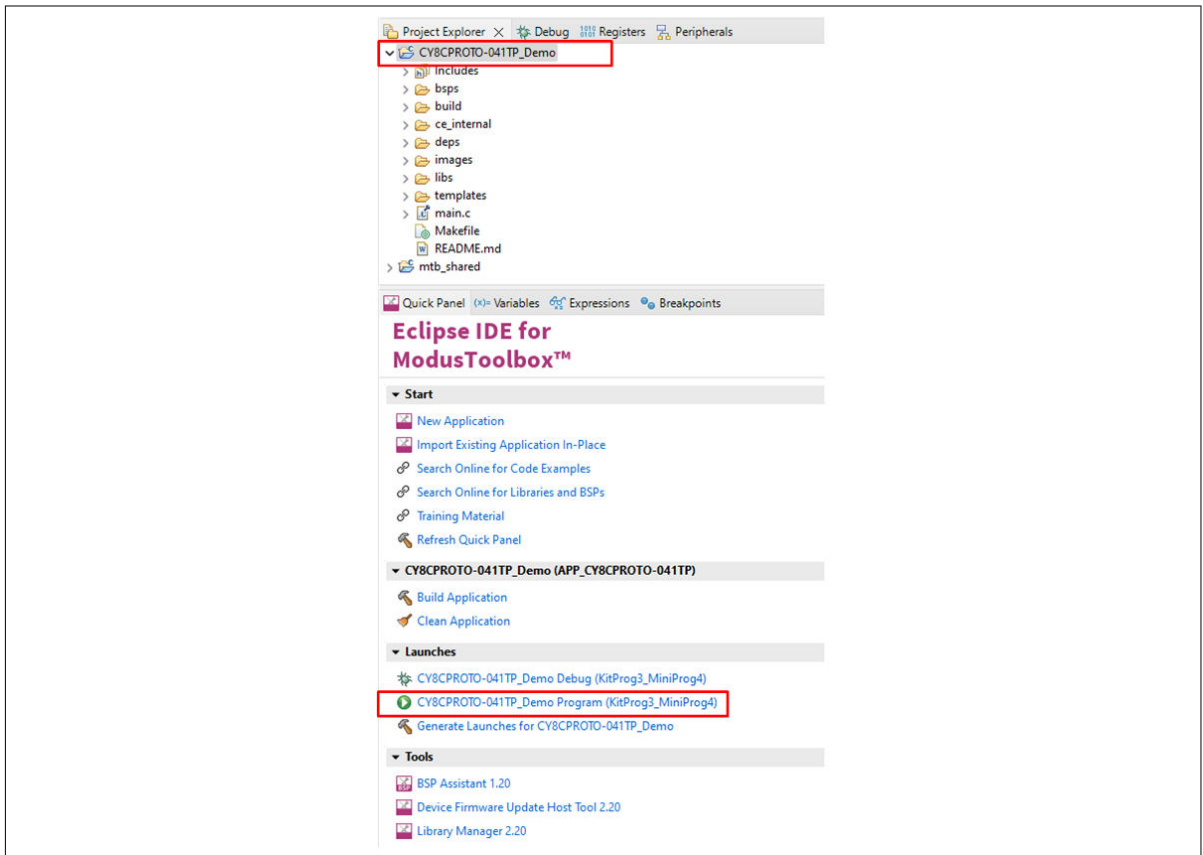

**Figure 16** Building and programming the code example

5. ModusToolbox™ has an integrated debugger. To debug the PSOC™ 4100T Plus device application, follow these steps:
  - a. In the **Project Explorer** tab, select the **<App\_Name>** project
  - b. In the **Quick Panel**, navigate to the **Launches** section, and click the **<App\_Name> Debug (KitProg3\_MiniProg4)** configuration, as shown in [Figure 18](#)

## 2 Kit operation

For a detailed explanation on how to debug using ModusToolbox™ software, see the “Program and debug” section in the [Eclipse IDE for ModusToolbox™ user guide](#).

**Note:** *Debug is disabled by default in the code example to reduce power consumption. Enable Debug in the Device Configurator, as shown in Figure 17.*

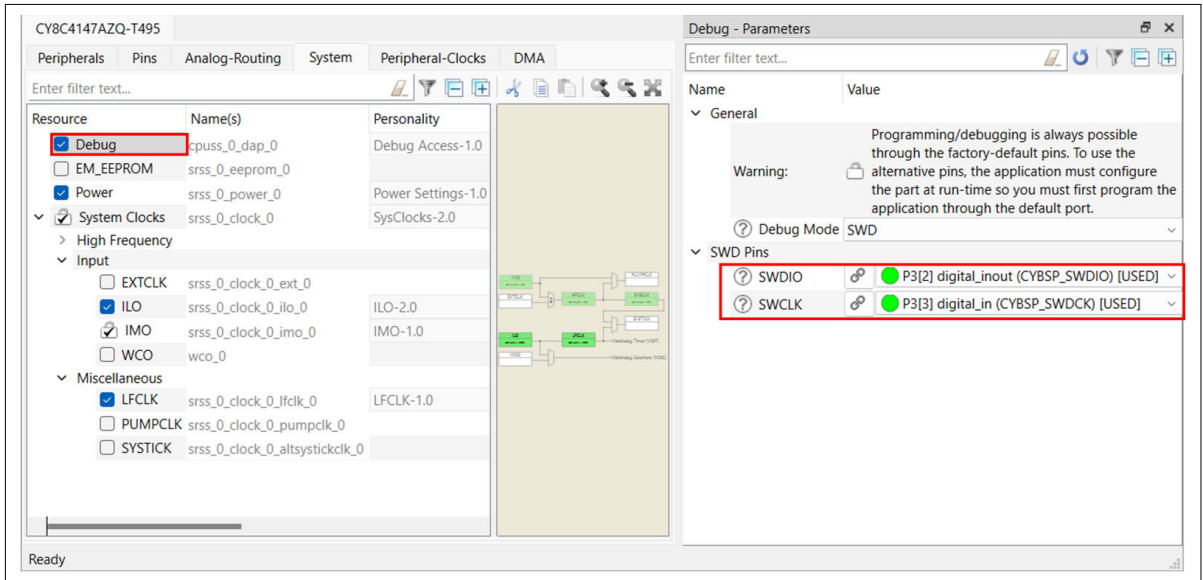

**Figure 17** Enabling Debug in the Device Configurator

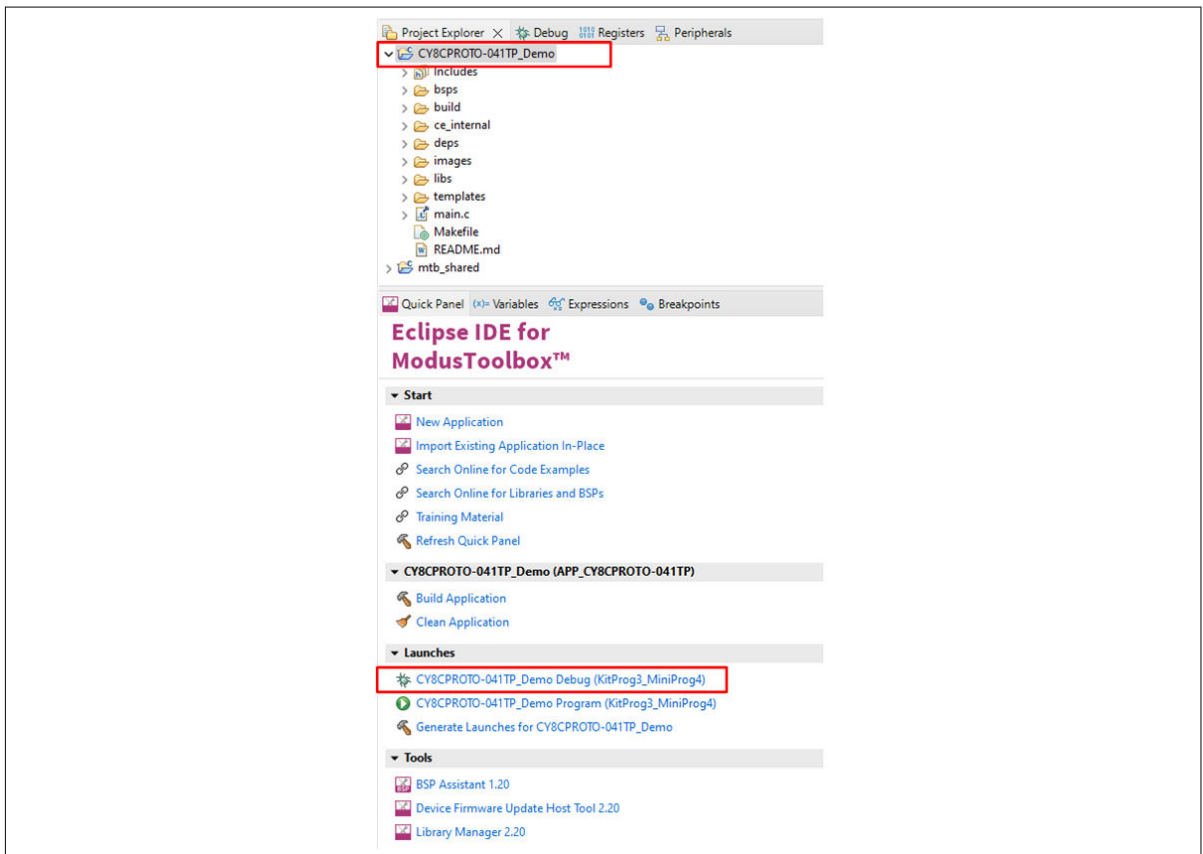

**Figure 18** Debugging the code example

## 3 Hardware

### 3 Hardware

#### 3.1 Schematics

See the schematic files available on the [kit webpage](#).

#### 3.2 Hardware functional description

This section describes the individual hardware blocks. The kit includes a PSOC™ 4100T Plus CAPSENSE™ Prototyping Board, which features the following components:

- PSOC™ 4100T Plus device
- KitProg3 programmer/debugger and bridge
- CAPSENSE™ buttons supporting CSD and CSX modes
- CAPSENSE™ proximity sensor
- CAPSENSE™ 4x5 touchpad supporting both CSX and CSD modes
- Sensor expansion header for interfacing additional sensor expansion boards
- Ambient light sensor
- Four user LEDs
- User button
- Other essential passive components for the operation of the kit

##### 3.2.1 PSOC™ 4100T Plus MCU features

This kit features the PSOC™ 4100T Plus MCU, a member of the PSOC™ 4 platform with scalable and reconfigurable architecture and an Arm® Cortex®-M0+ CPU. It combines a high-performance capacitive sensing subsystem with programmable, reconfigurable analog and digital blocks.

For more information, see the PSOC™ 4100T Plus MCU family datasheet.

3 Hardware

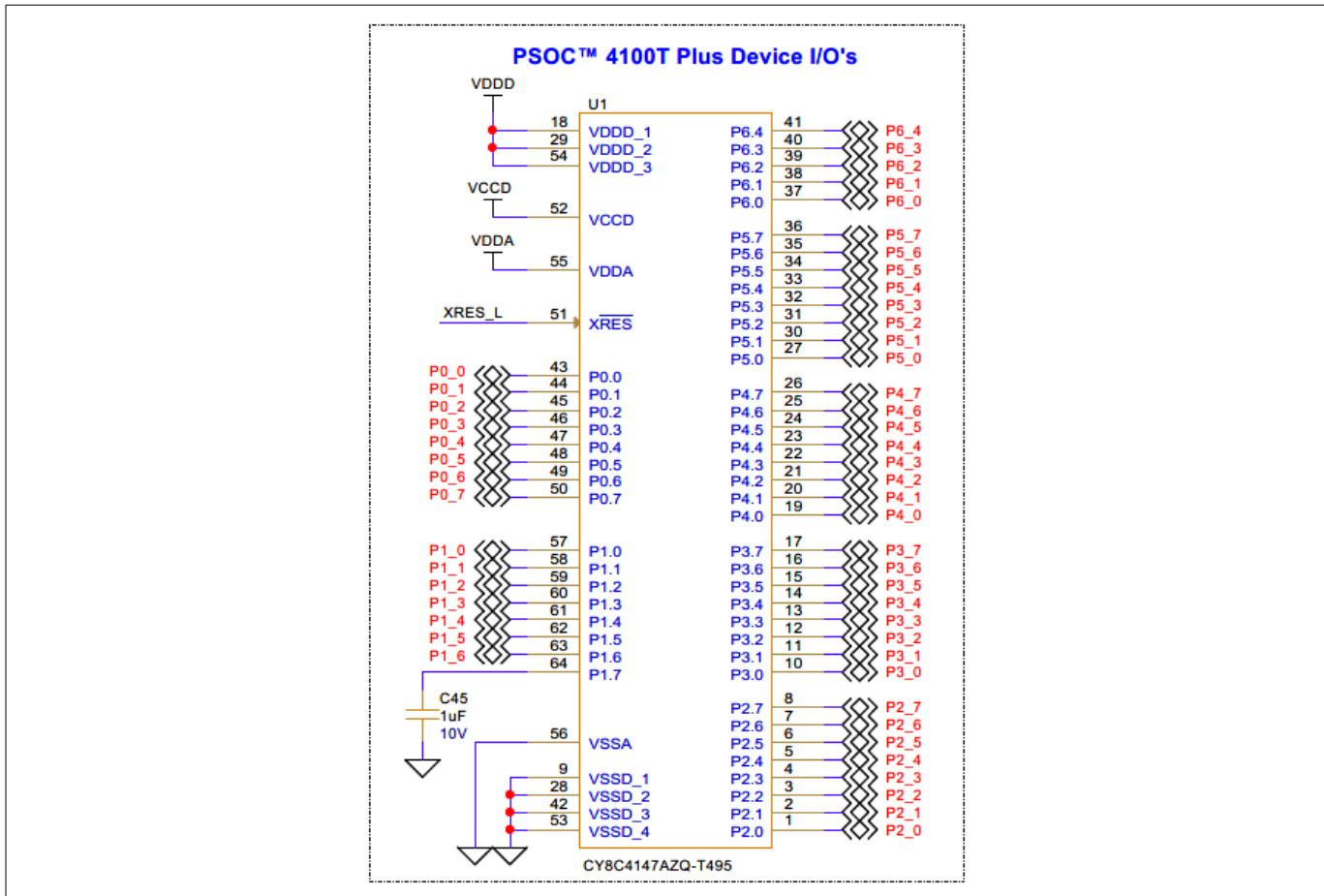

Figure 19 PSOC™ 4100T Plus MCU schematic

Table 3 Pin assignment of PSOC™ 4100T Plus MCU in the Prototyping Kit

Pin details	Primary onboard function	Secondary onboard function
P0[0]	CAPSENSE™ driven shield 1 (SHIELD1)	–
P0[1]	CAPSENSE™ proximity sensor (CSP1)	–
P0[2]	–	WCO IN
P0[3]	–	WCO OUT
P0[4]	CAPSENSE™ touchpad row 3 (CST1_R3)	–
P0[5]	CAPSENSE™ touchpad row 2 (CST1_R2)	–
P0[6]	CAPSENSE™ touchpad row 1 (CST1_R1)	–
P0[7]	CAPSENSE™ touchpad row 0 (CST1_R0)	–
P1[0]	CAPSENSE™ CMOD1	–
P1[1]	CAPSENSE™ CMOD2	–
P1[2]	CAPSENSE™ touchpad column 4 (CST1_C4)	–
P1[3]	CAPSENSE™ touchpad column 3 (CST1_C3)	–
P1[4]	CAPSENSE™ touchpad column 2 (CST1_C2)	–
P1[5]	CAPSENSE™ touchpad column 1 (CST1_C1)	–

(table continues...)

## 3 Hardware

**Table 3 (continued) Pin assignment of PSOC™ 4100T Plus MCU in the Prototyping Kit**

Pin details	Primary onboard function	Secondary onboard function
P1[6]	CAPSENSE™ touchpad column 0 (CST1_C0)	–
P1[7]	SAR ADC External VREF input (connected to a capacitor)	–
P2[0] - P2[6]	–	Connected to a Multi-Sense expansion connector (J24), which can be used as: <ul style="list-style-type: none"> <li>• General-purpose I/O</li> <li>• CAPSENSE™ I/O</li> <li>• SAR ADC input</li> </ul>
P2[7]	Ambient light sensor output (SAR ADC input)	Connected to a Multi-Sense expansion connector (J24), which can be used as: <ul style="list-style-type: none"> <li>• General-purpose I/O</li> <li>• CAPSENSE™ I/O</li> <li>• SAR ADC input</li> </ul>
P3[1]	–	Connected to a Multi-Sense expansion connector (J24), which can be used as: <ul style="list-style-type: none"> <li>• General-purpose I/O</li> <li>• CAPSENSE™ I/O</li> </ul>
P3[2]	SWD interface data I/O – SWDIO	–
P3[3]	SWD interface clock – SWDCLK	–
P4[0] - P4[2]	–	Connected to a Multi-Sense expansion connector (J24), which can be used as: <ul style="list-style-type: none"> <li>• General-purpose I/O</li> <li>• CAPSENSE™ I/O</li> </ul>
P4[3]	CAPSENSE™ driven shield 2 (SHIELD2)	–
P4[4]	CAPSENSE™ CSX button RX (CSB2_RX)	–
P4[5]	CAPSENSE™ CSD button (CSD_BTN)	–
P4[6]	CAPSENSE™ CSX button TX (CSB2_TX)	–
P5[1]	KitProg3 UART interface TX (KP_UART_TX)	–
P5[2]	KitProg3 UART interface RX (KP_UART_RX)	–
P5[4]	User LED 2 (LED3)	–
P5[5]	User LED 1 (LED2)	–
P5[6]	User button	–
P6[0]	User LED 3 (LED5)	–

**(table continues...)**

## 3 Hardware

**Table 3 (continued) Pin assignment of PSOC™ 4100T Plus MCU in the Prototyping Kit**

Pin details	Primary onboard function	Secondary onboard function
P6[2]	User LED 4 (LED6)	Connected to an external sensor interface expansion header (J24), which can be used as: <ul style="list-style-type: none"> <li>• General-purpose I/O</li> <li>• PWM Output</li> <li>• SPI MOSI</li> </ul>
P6[3]	KitProg3 I <sup>2</sup> C interface clock (KP_ SCL)	Connected to an external sensor interface expansion header (J24), which can be used as: <ul style="list-style-type: none"> <li>• I2C SCL</li> </ul>
P6[4]	KitProg3 I <sup>2</sup> C interface data (KP_ SDA)	Connected to an external sensor interface expansion header (J24), which can be used as: <ul style="list-style-type: none"> <li>• I2C SDA</li> </ul>
XRES	Hardware reset	–

### 3.2.1.1 PSOC™ 4100T Plus MCU power

The PSOC™ 4100T Plus MCU has two distinct modes of operation, each with specific power supply requirements. In Mode 1, the chip can be powered by an external power supply ranging from 2.0 V to 5.5 V, making it ideal for battery-powered operation. The internal regulator of the PSOC™ 4100T Plus MCU supplies the internal logic, with its output connected to the VCCD pin. To ensure proper functioning, the VCCD pin must be bypassed to ground using an external 2.2 μF capacitor (X5R ceramic or better). It must not be connected to anything else.

## 3 Hardware

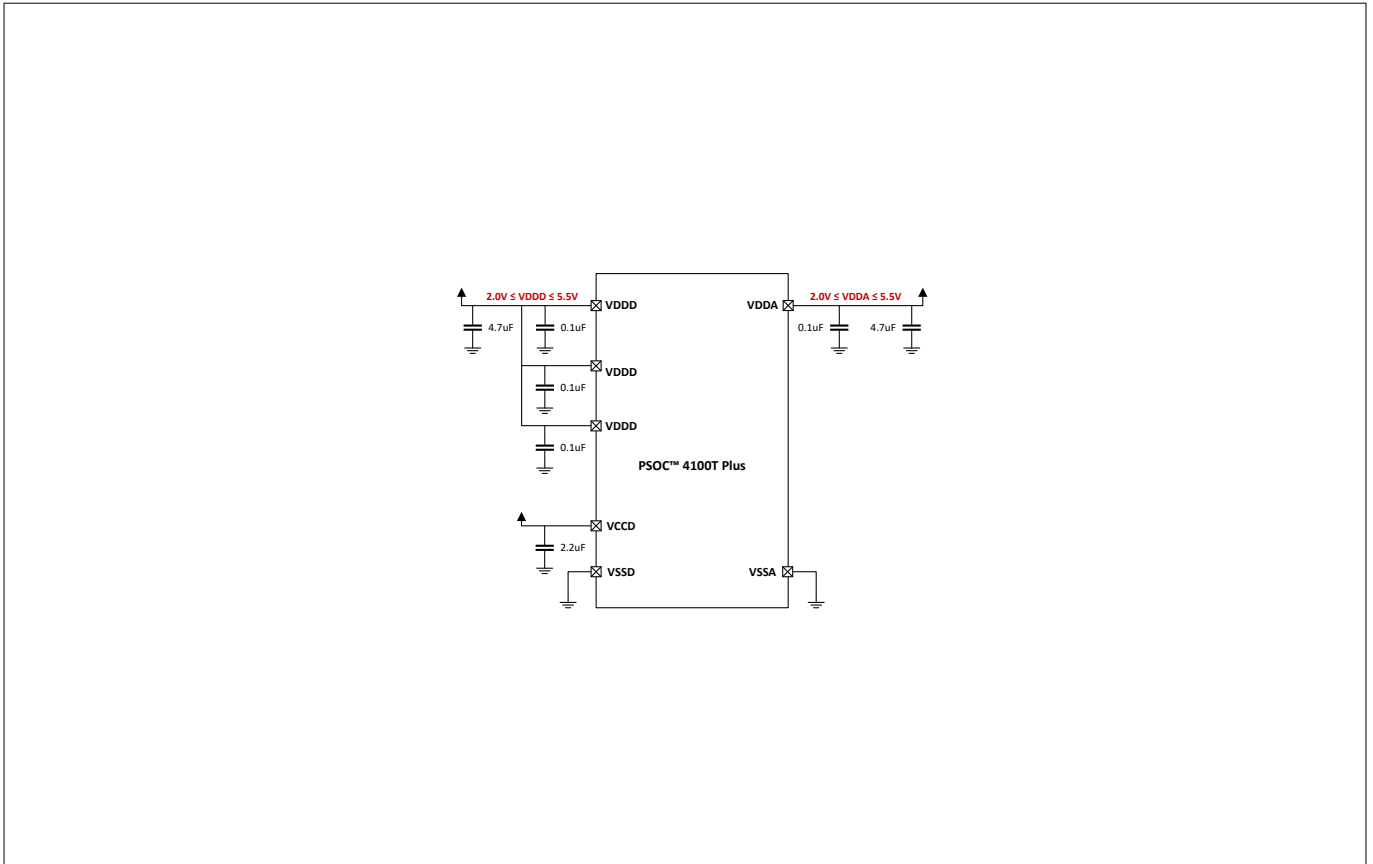

**Figure 20 PSOC™ 4100T Plus MCU schematic with 2.0 V to 5.5 V external supply**

In Mode 2, the power supply must be externally regulated and within the range of 1.71 V to 1.89 V, including power supply ripple. In this mode, the VDD and VCCD pins are shorted together and bypassed. The internal regulator must remain enabled. For optimal bypassing, use bypass capacitors from VDD to ground. It is standard practice to use a larger capacitor in parallel with a smaller capacitor (for example, 0.1 µF).

## 3 Hardware

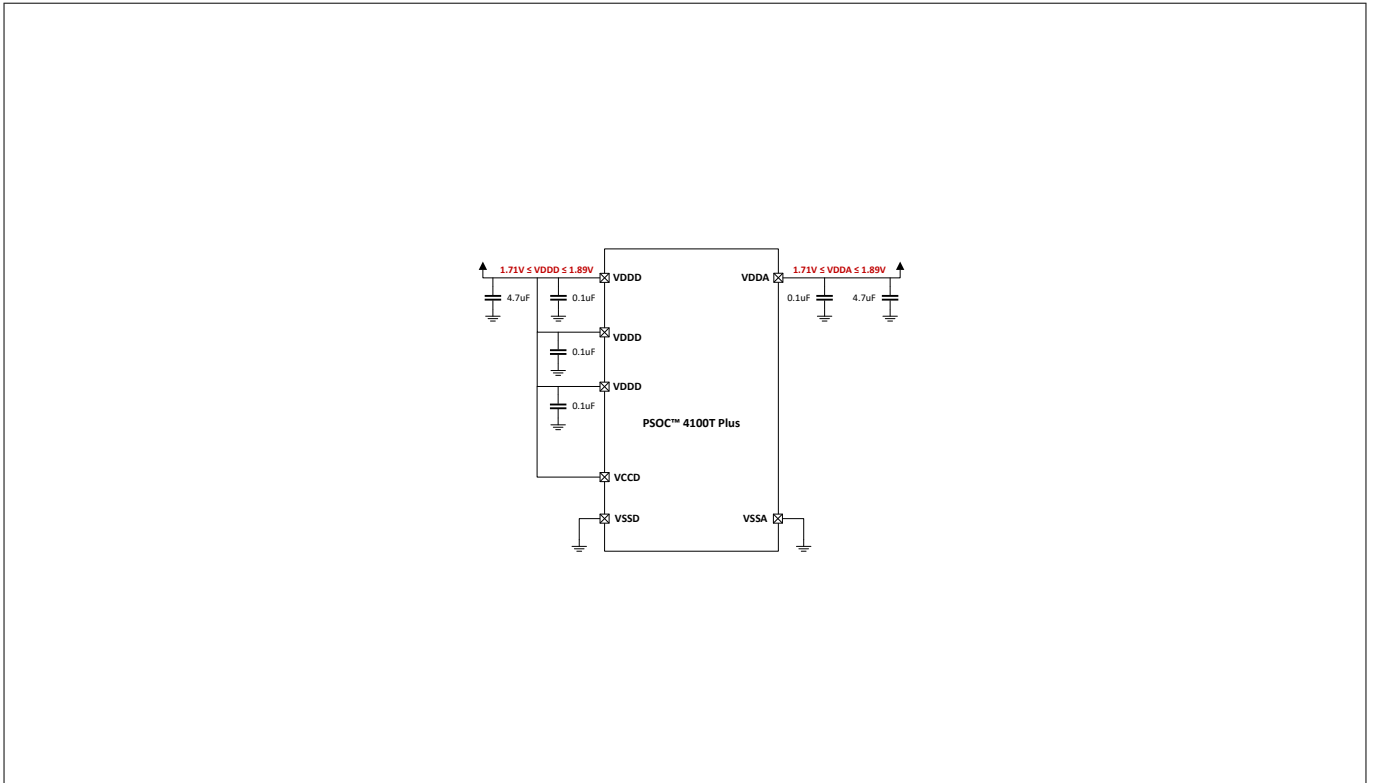

**Figure 21 PSOC™ 4100T Plus MCU schematic with 1.8 V ±5% external supply**

The PSOC™ 4100T Plus MCU on the prototyping board operates at 5 V in the default configuration (Mode 1). The target voltage for the PSOC™ 4100T Plus MCU is supplied through a ferrite bead (FB4) to filter noise on the power rail. Provisions are available for powering the kit, allowing the target MCU voltage to be configured to operate at 1.8 V either by feeding 1.8 V through an external power input or by enabling a 1.8 V LDO voltage-regulated supply. For 1.8 V operation, the VCCD (core-voltage supply) of the PSOC™ 4100T Plus MCU must be shorted with VDDDD by populating R67 or by populating a J14 header and shorting it with a jumper (ACC18). The default configuration supports both 3.3 V and 5 V operation.

3 Hardware

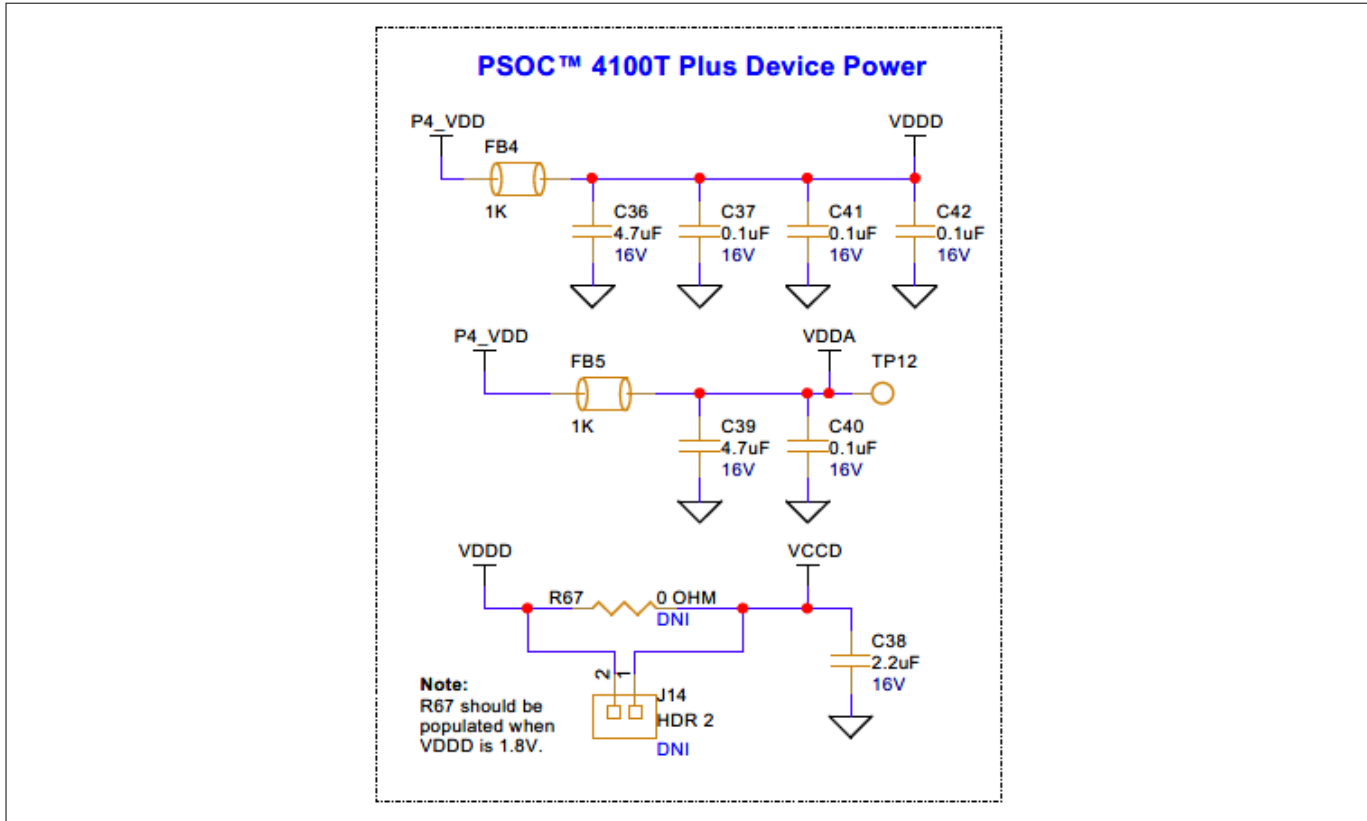

**Figure 22 PSOC™ 4100T Plus MCU power schematic**

A set of decoupling capacitors is provided for both the digital (VDDD) and core (VCCD) voltage rails of the MCU. To measure the current consumption in different modes of operation for the PSOC™ 4100T Plus target device, use header J2 in the power rail. By default, J2 is shorted with a jumper (ACC7).

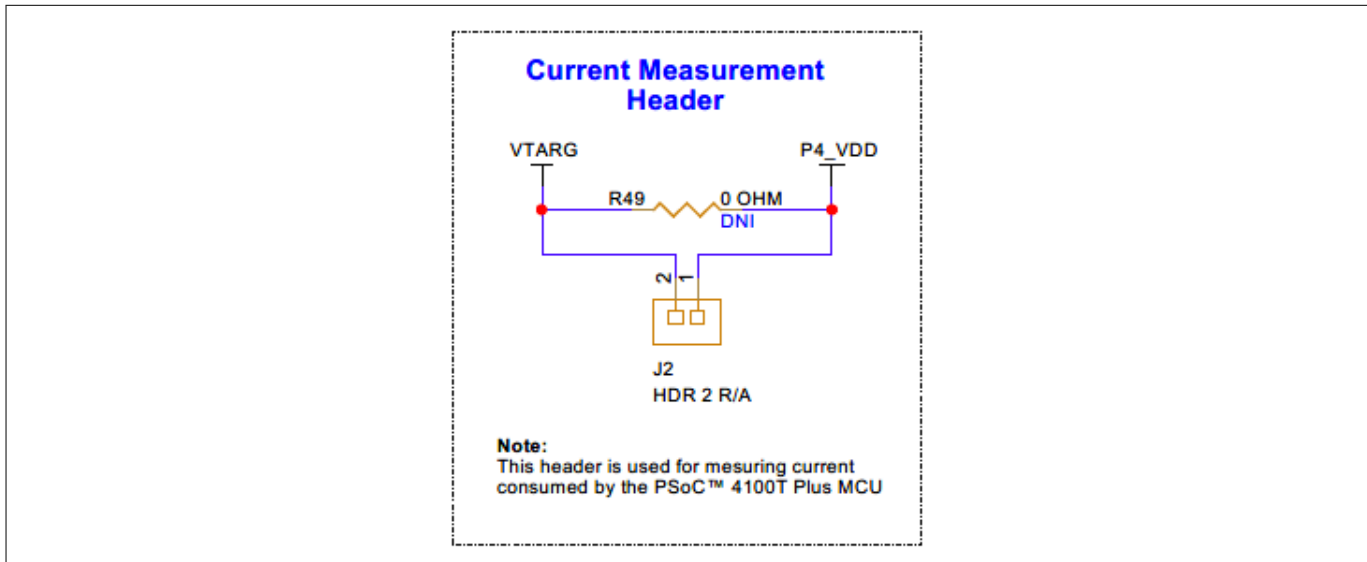
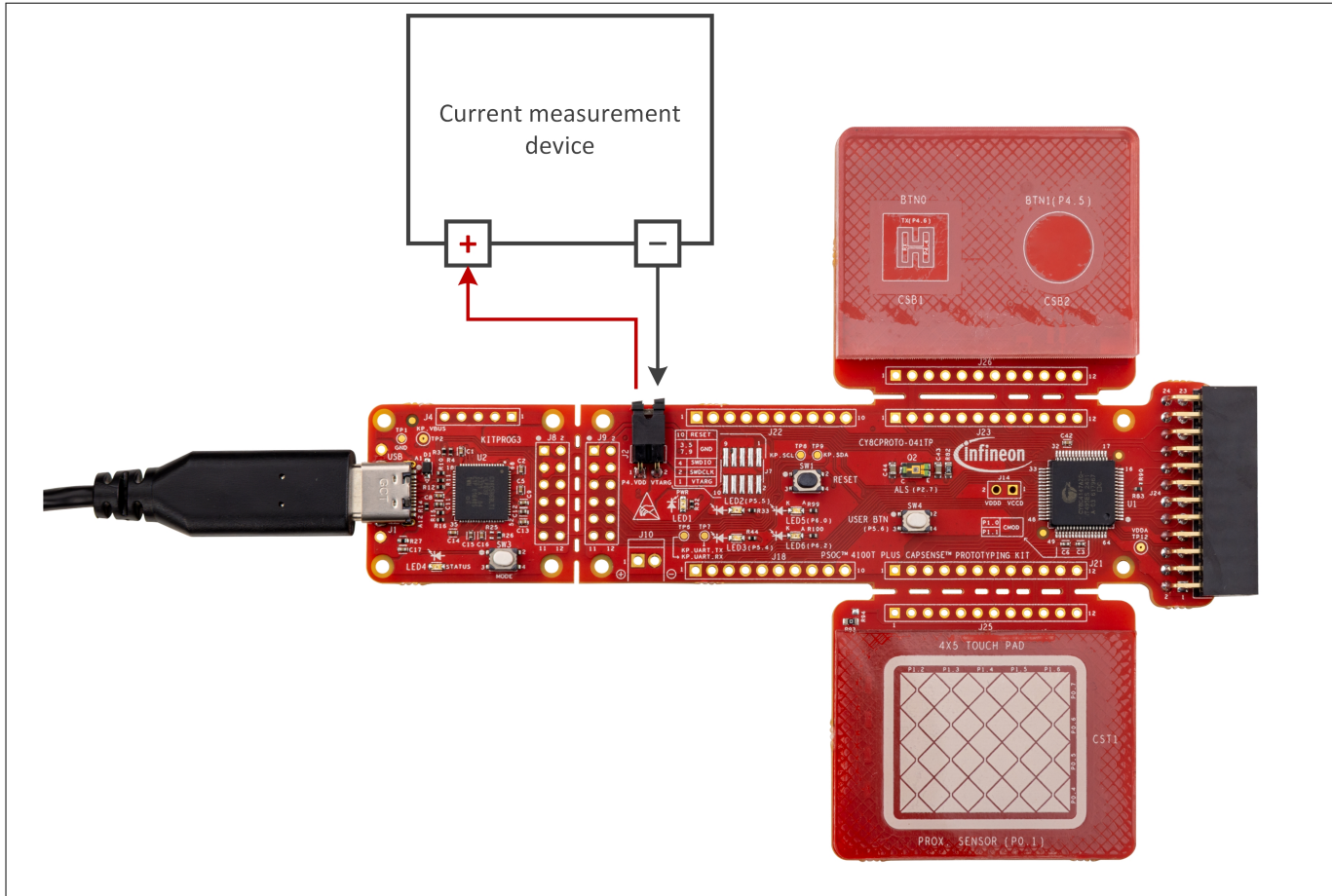

**Figure 23 Current measurement header (J2) schematic**

For current measurement, remove the jumper and connect a current measurement device (ammeter) between the pins of J2, as shown in Figure 23.

**Note:** Do not remove the jumper while the target device is powered.

3 Hardware



**Figure 24** Connecting the current measurement device with the J2 header

The onboard LED (LED1) indicates the power status of the PSOC™ 4100T Plus MCU.

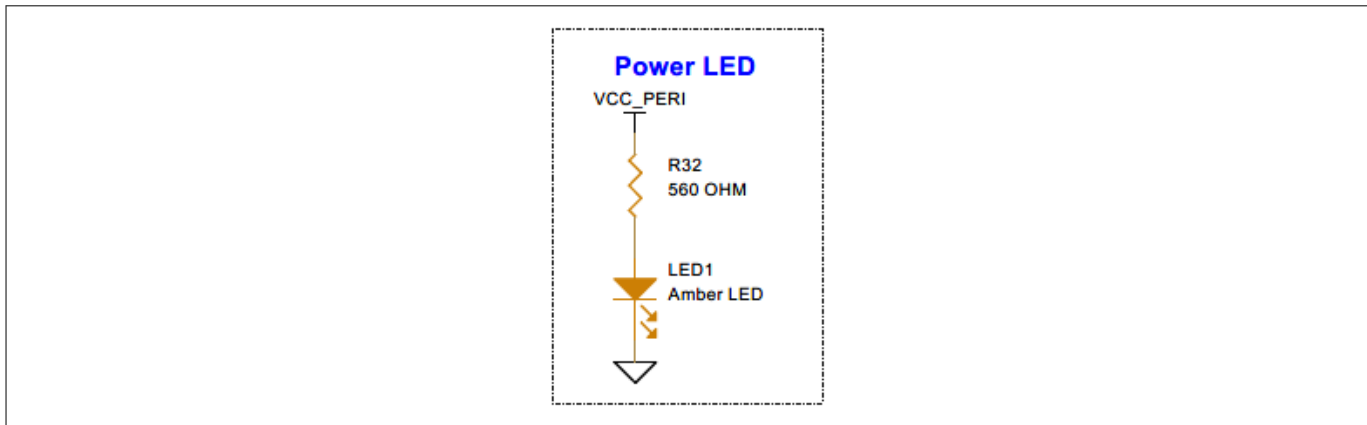

**Figure 25** Schematic of power LED indication (LED1)

**3.2.1.2 PSOC™ 4100T Plus MCU external programming/debugging header**

On the PSOC™ 4100T Plus Prototyping Board, the default programming/debugging interface is provided by the onboard KitProg3 programmer/debugger. Additionally, you can use an external MiniProg4 programmer/debugger through the 10-pin header (J7) provision, which is not populated by default.

3 Hardware

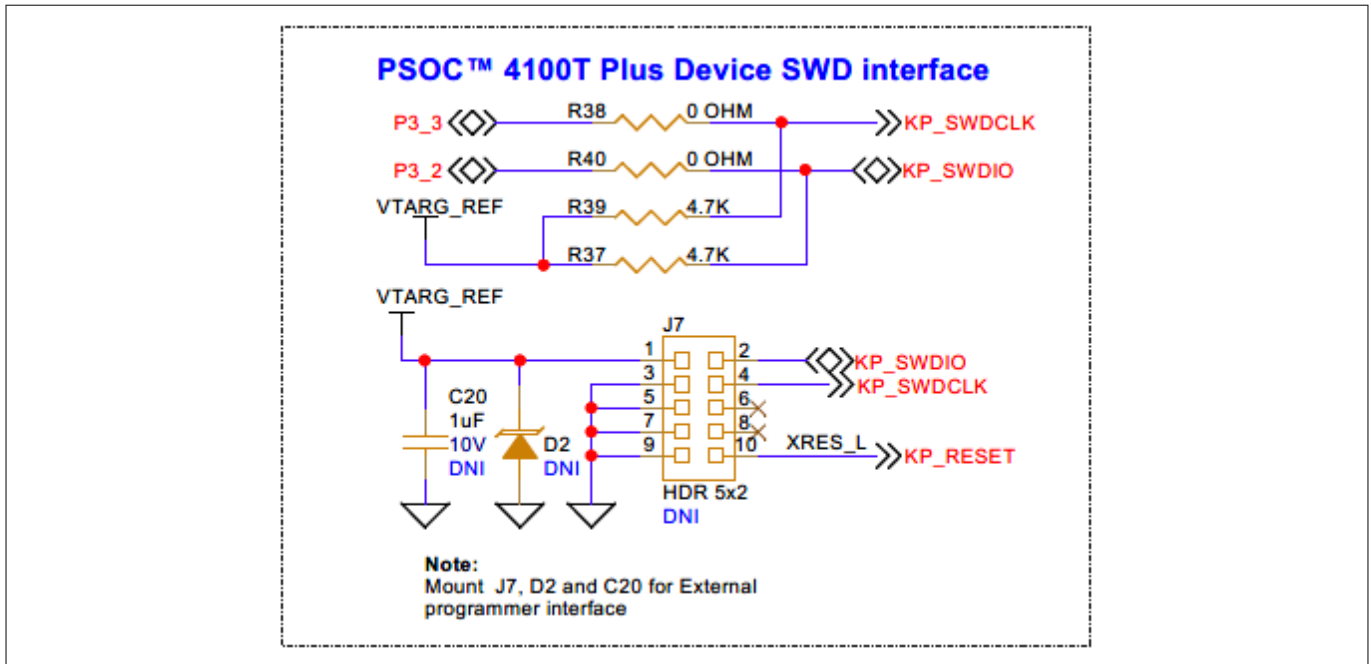

Figure 26 PSOC™ 4100T Plus MCU 10-pin programming/debugging header schematic

To use the external programming/debugging interface, populate J7, D2, and C20.

3.2.1.3 Reset button

Use the push button (SW1) on the PSOC™ 4100T Plus CAPSENSE™ Prototyping Board to reset the PSOC™ 4100T Plus MCU. SW1 provides an active LOW signal.

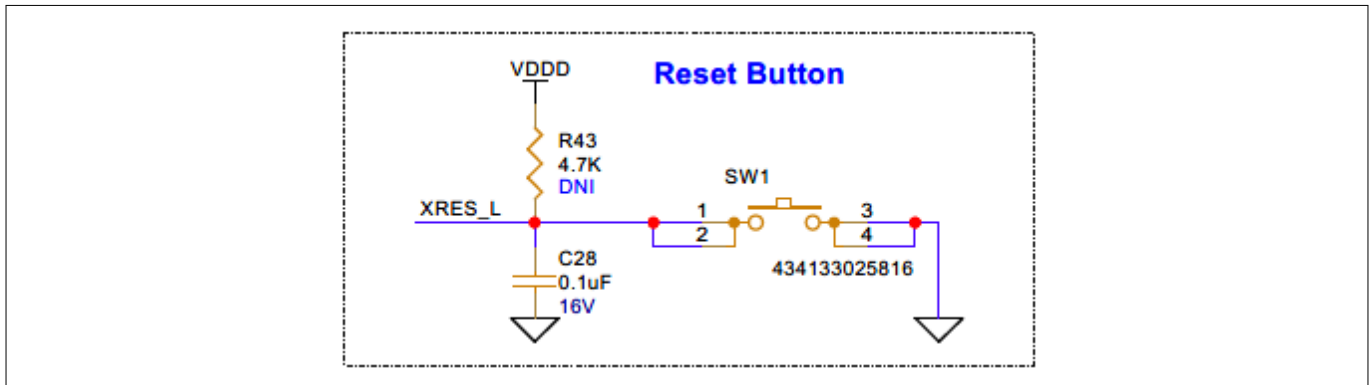

Figure 27 Reset button (SW1) schematic

3.2.2 PSOC™ 5LP-based KitProg3 programmer and debugger

An onboard PSOC™ 5LP device (CY8C5868LTI-LP039 - U2) functions as the KitProg3 programmer/debugger to program and debug the PSOC™ 4100T Plus device. The PSOC™ 5LP device connects to the PC's USB port via a Type-C USB connector and interfaces with the SWD and other communication interfaces of the PSOC™ 4100T Plus MCU.

For more information, refer to the following resources:

- [PSOC™ 5LP webpage](#)
- [CY8C58LPxx family datasheet](#)

3 Hardware

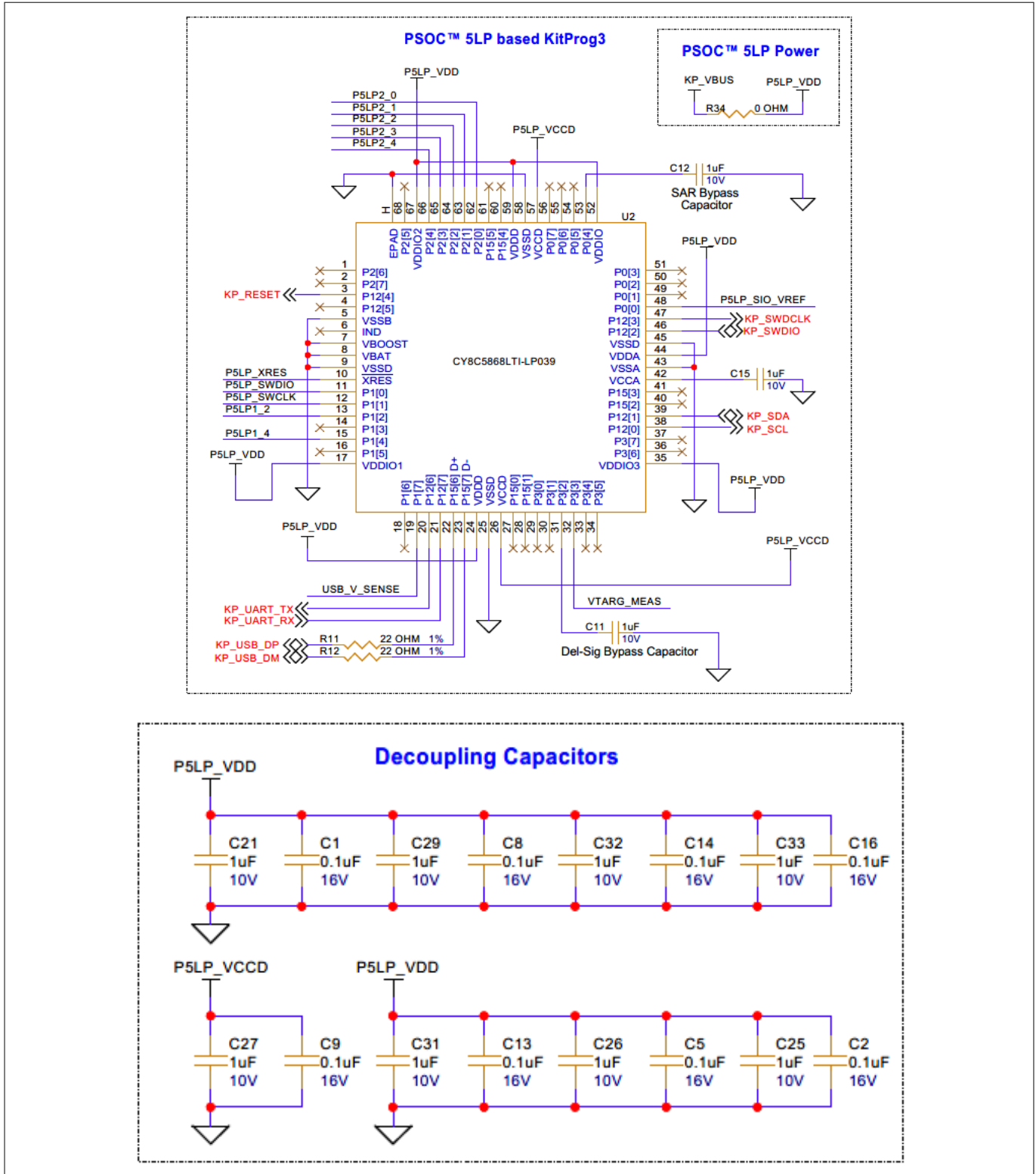

Figure 28 Schematic of PSOC™ 5LP-based KitProg3

3.2.2.1 KitProg3 onboard target voltage measurement

PSOC™ 5LP of KitProg3 uses an ADC to measure the onboard target voltage. A voltage divider is placed before the ADC input to ensure the target voltage is within the dynamic range of the ADC.

3 Hardware

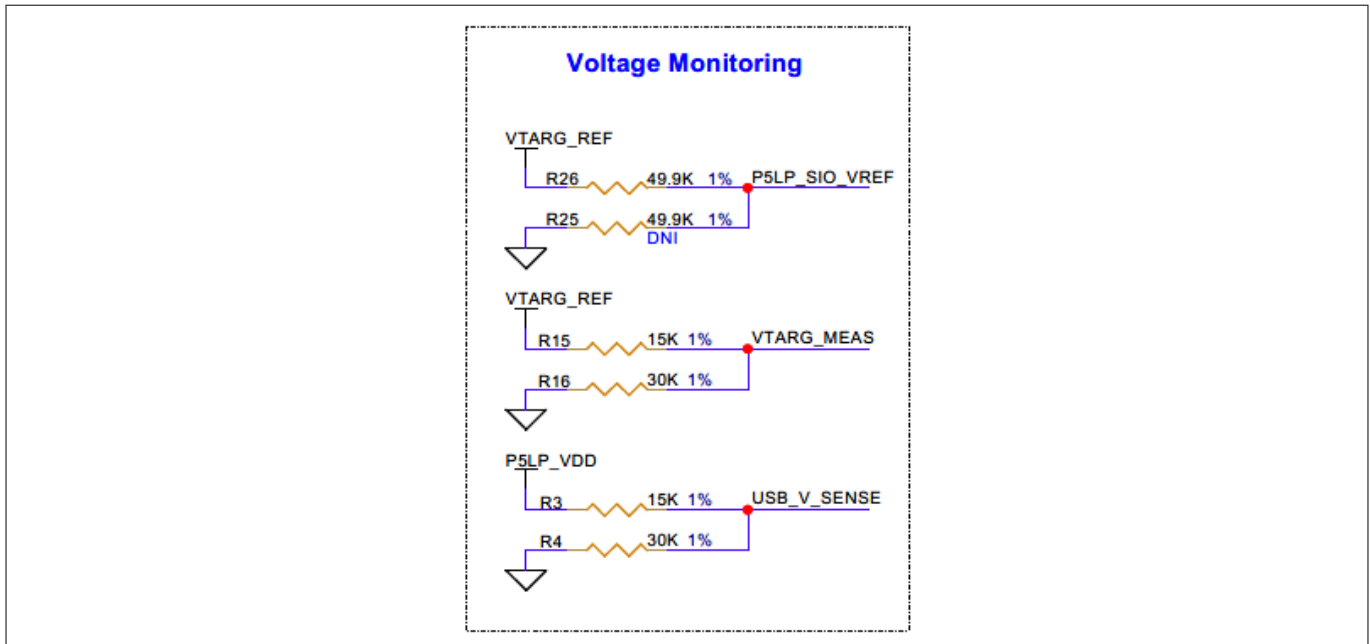

Figure 29 Schematic of KitProg3 onboard target voltage monitoring circuit

3.2.2.2 KitProg3 programming mode selection button and status LED

Use the SW3 button to switch between various modes of KitProg3 operation, such as from CMSIS-DAP HID to BULK mode and enabling the boot loader mode. By default, KitProg3 on this board supports CMSIS-DAP BULK mode. The SW3 button is also reserved for future use. The status LED (LED4) indicates the current mode of KitProg3.

For more details, see the [KitProg3 user guide](#).

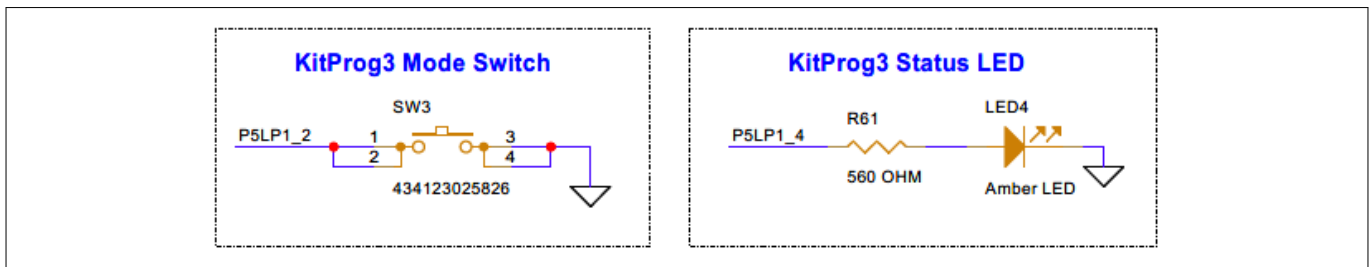

Figure 30 KitProg3 mode selection button (SW3) and status LED (LED4) schematic

3.2.3 Power supply system

This prototyping board has a default input supply from the USB Type-C connector (J1), with low-capacitance bidirectional TVS diodes (D1 and U3). These diodes provide ESD and overvoltage transient protection for both power and data signals. Additionally, they provide the 5 V supply for the target MCU through a ferrite bead (FB1).

Figure 31 shows the power block diagram of the PSOC™ 4100T Plus CAPSENSE™ Prototyping Board with the default input supply.

3 Hardware

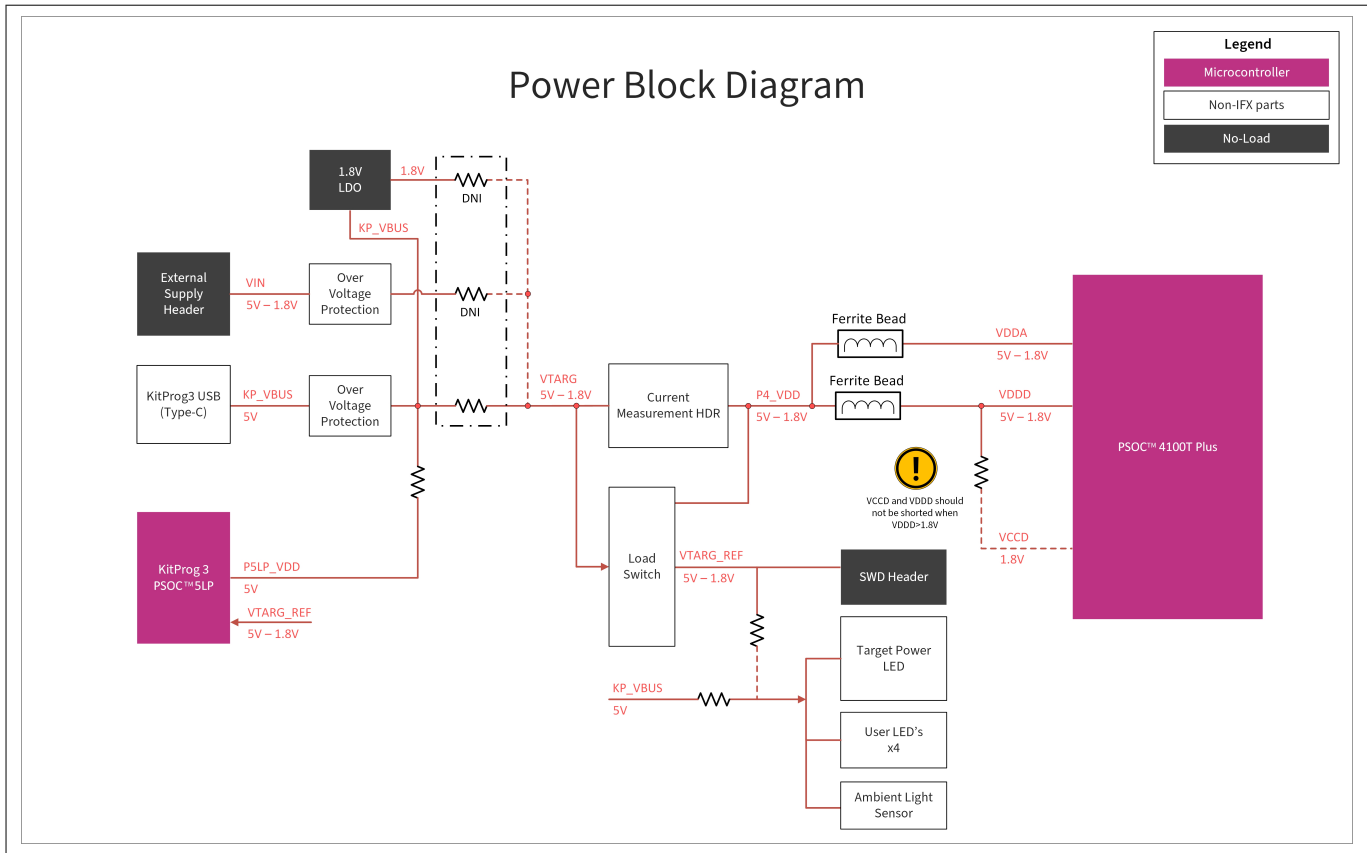

Figure 31 Power block diagram

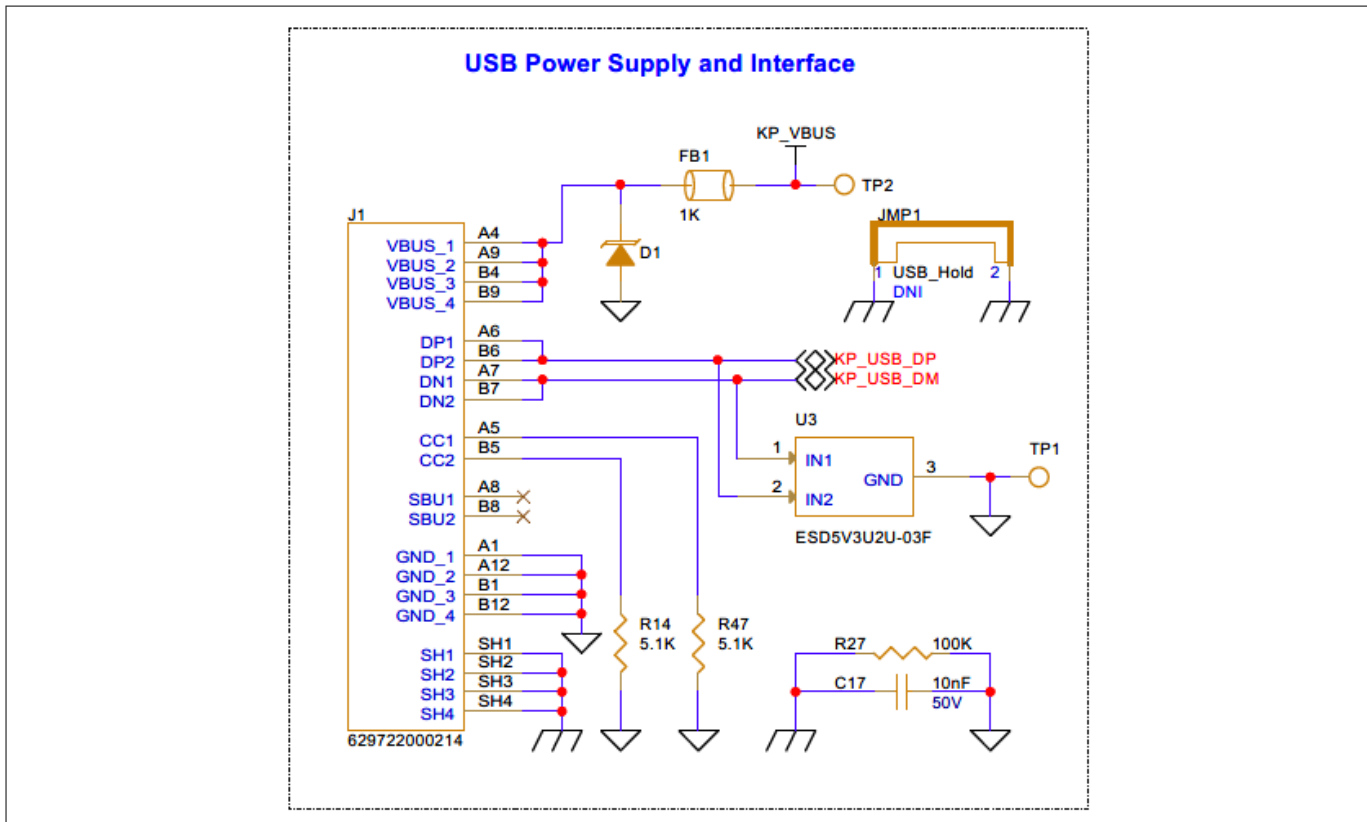

Figure 32 USB Type-C connector (J1) and ESD protection (D1, U3) schematic

3 Hardware

This board has a linear voltage regulator at U4 to provide the PSOC™ 4100T Plus device with a regulated 1.8 V supply, derived from the 5 V supply coming from the USB Type-C connector.

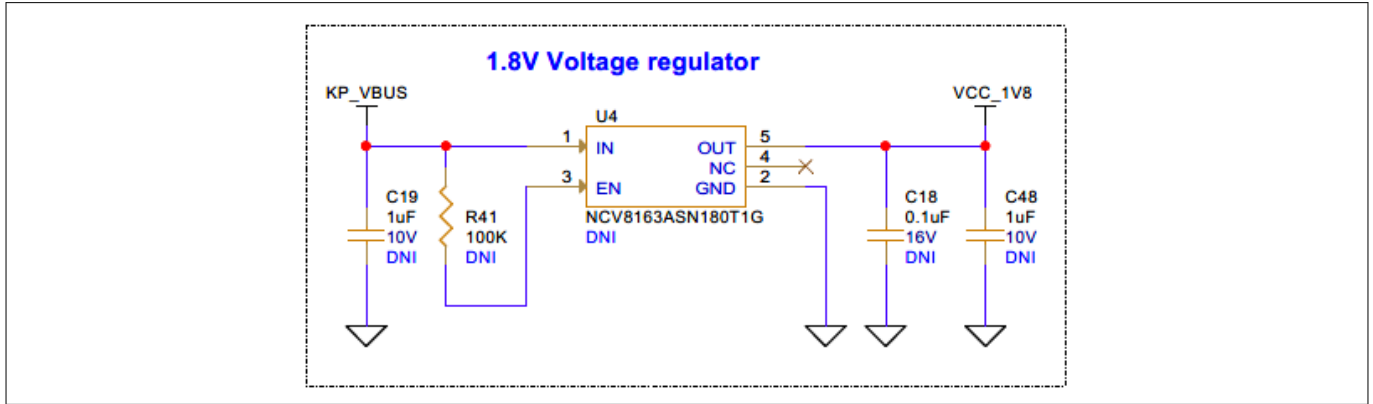

Figure 33 1.8 V voltage regulator (U4) schematic

Header J10 (not populated by default) can be used as an external power supply input to power the PSOC™ 4100T Plus device with a voltage ranging from 1.8 V to 5 V.

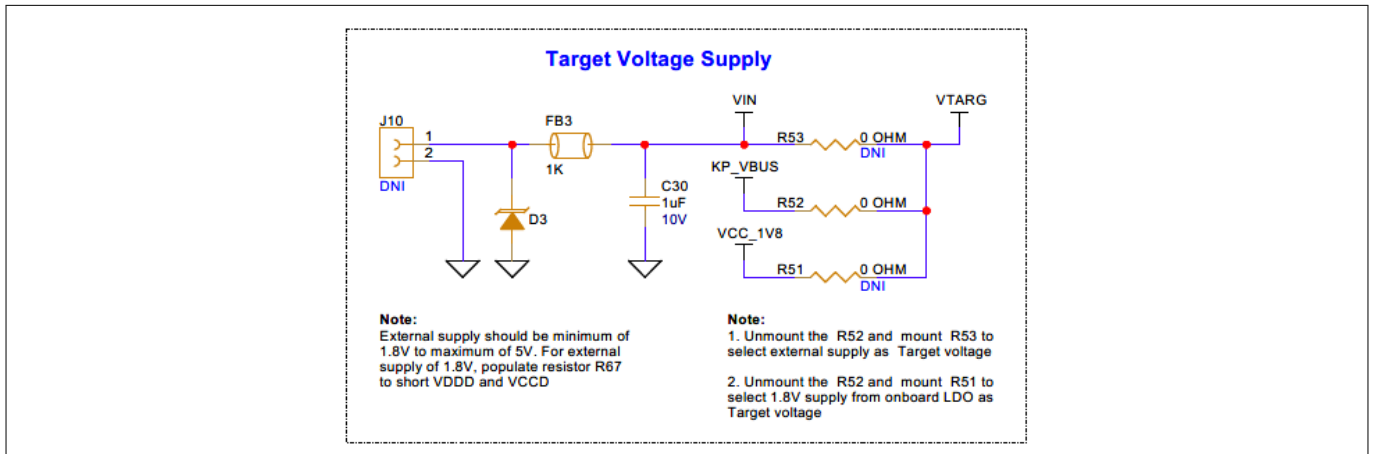

Figure 34 External power supply input (J10) schematic

These powering options allow the kit to operate at different voltages. Select the required powering option by populating the corresponding selection resistors (R53, R52, or R51).

**Note:** If the supply voltage (VDDD) is 1.8 V, short the PSOC™ 4100T Plus device core supply (VCCD) with VDDD using resistor R67, as shown in PSOC™ 4100T Plus MCU power.

3 Hardware

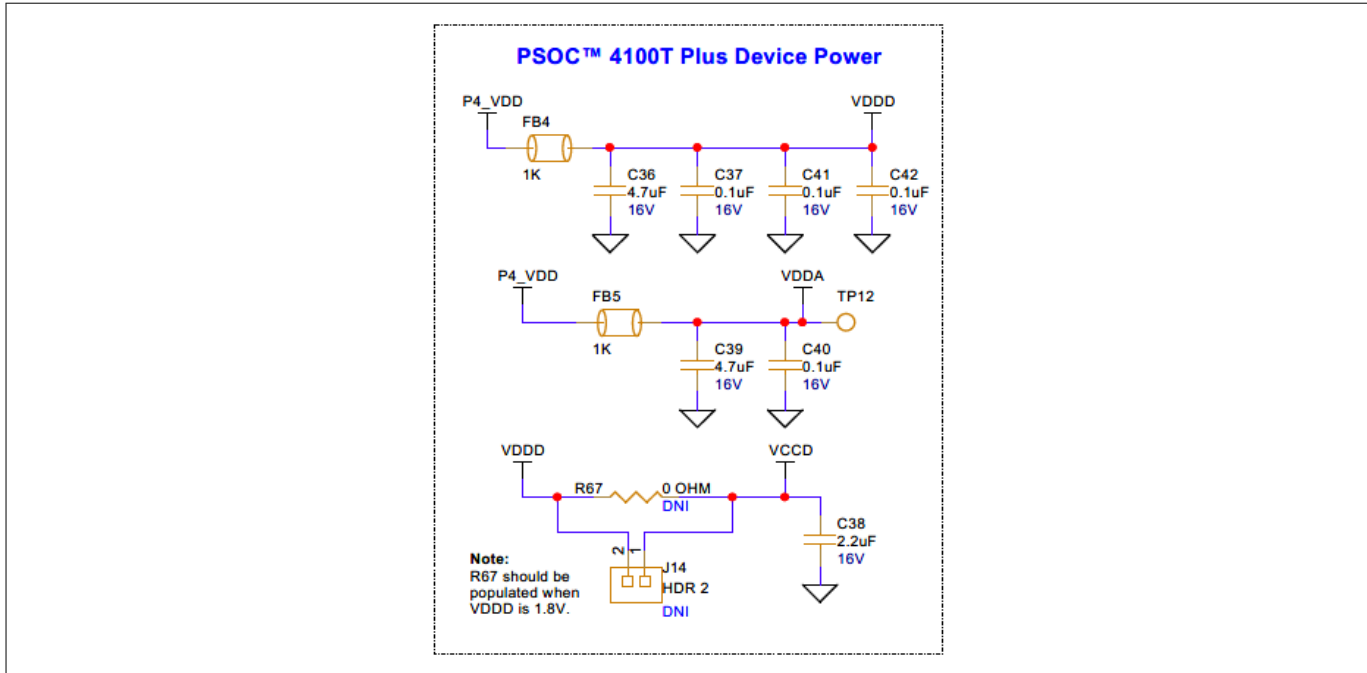

Figure 35 PSOC™ 4100T Plus device power schematic

3.2.3.1 Target reference voltage switch

A load switch (U5) is used to generate the target reference voltage and to isolate the leakage currents from the voltage divider used for target voltage measurement.

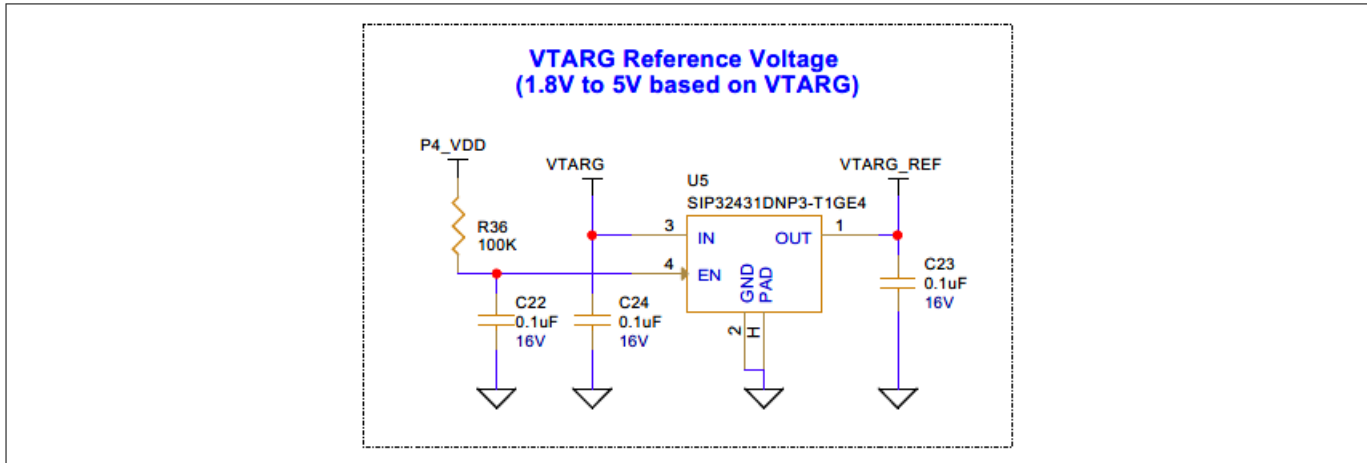

Figure 36 Target reference voltage switch (U5) schematic

3.2.4 CAPSENSE™

3.2.4.1 Capacitive sensing

The PSOC™ 4100T Plus CAPSENSE™ Prototyping Board includes:

- A 4x5 segment CAPSENSE™ touchpad (CST1) that supports both CSX and CSD modes
- Two CAPSENSE™ buttons (CSB1 and CSB2), with CSB1 supporting both CSD and CSX modes, and CSB2 supporting only CSD mode
- A proximity sensor (CSP1)

3 Hardware

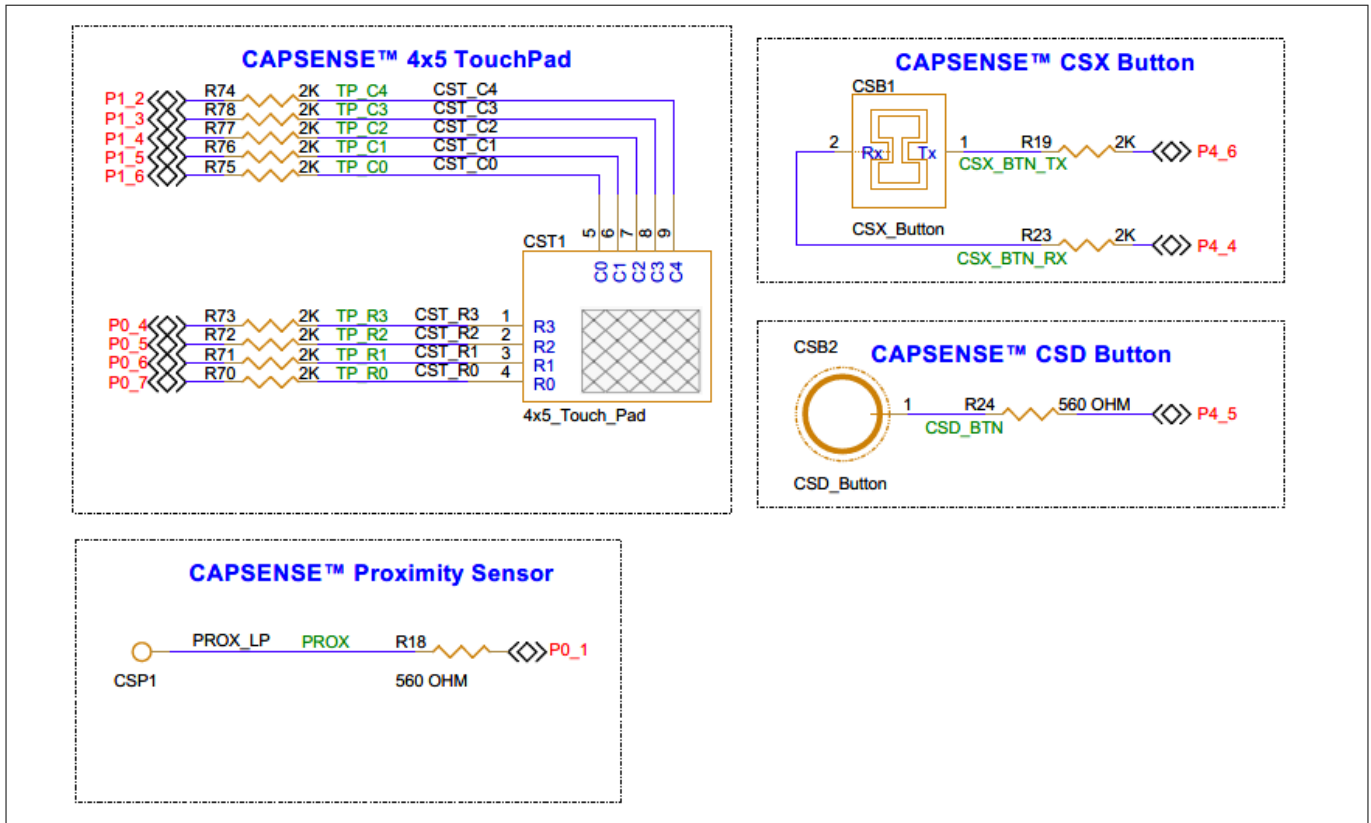

Figure 37 Schematic of capacitive sensing widgets

The kit includes acrylic overlays of varying thicknesses to evaluate the performance of the CAPSENSE™ touchpad (CST1) and proximity sensor (CSP1) in different scenarios:

- 1. Default configuration:** A 1 mm thick acrylic overlay (ACC15) is provided for the initial evaluation of CAPSENSE™ performance
- 2. Optional configuration for evaluation with higher thickness overlay:** An additional 3 mm thick acrylic overlay (ACC17) is included in the kit. This can be placed on top of the existing 1 mm overlay to evaluate CAPSENSE™ touchpad performance in CSD mode with a higher thickness

The CAPSENSE™ buttons (CSB1 and CSB2) use a 4 mm (with -10% tolerance) thick acrylic overlay (ACC16) for evaluation purposes.

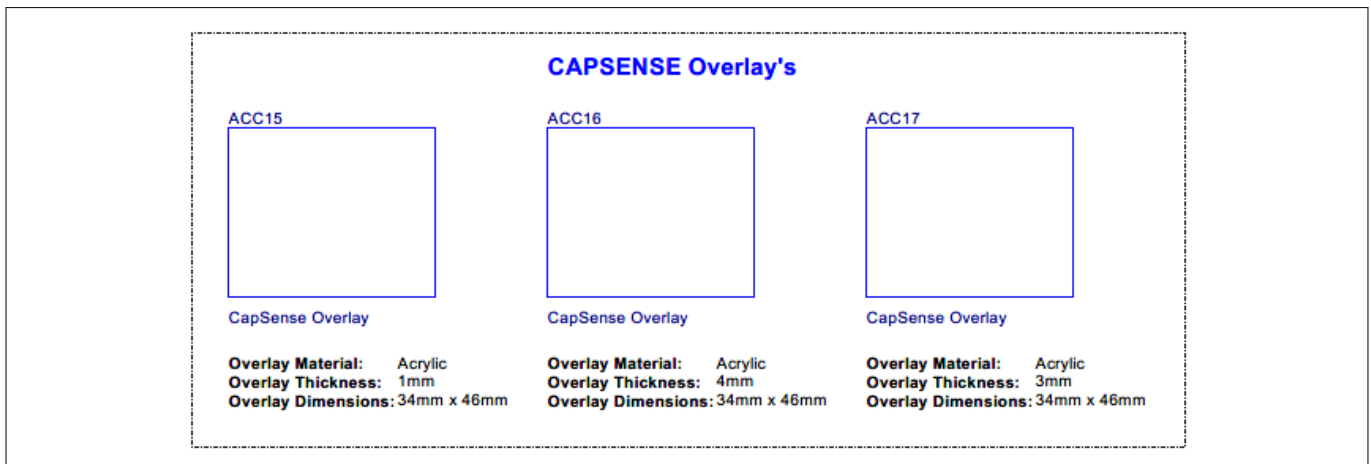
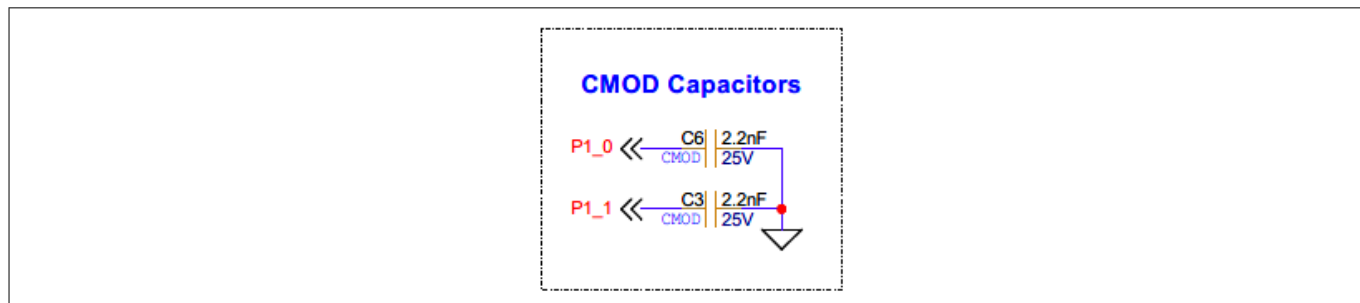

Figure 38 Acrylic overlays for CAPSENSE™ widgets

## 3 Hardware

Two external modulation capacitors (C3 and C6) on the board enable the CAPSENSE™ functionality. NPO dielectric-based capacitors are used for better capacitance tolerance over a temperature range of -55°C to +125°C.



**Figure 39 Schematic of modulation capacitors**

The board supports a dedicated set of driven shields that can drive the hatch pattern surrounding the sensor region. These hatch patterns had a provision to connect ground by default; all the hatch patterns are connected to the driven shields.

**Table 4 CAPSENSE™ widgets with their associated driven shield**

CAPSENSE™ widget	Associated driven shield	MCU I/O configured as driven shield
CAPSENSE™ touchpad (CST1)	SHIELD1	P0[0]
CAPSENSE™ proximity sensor (CSP1)	SHIELD1	P0[0]
CSX CAPSENSE™ button (CSB1)	SHIELD2	P4[3]
CSD CAPSENSE™ button (CSB2)	SHIELD2	P4[3]

3 Hardware

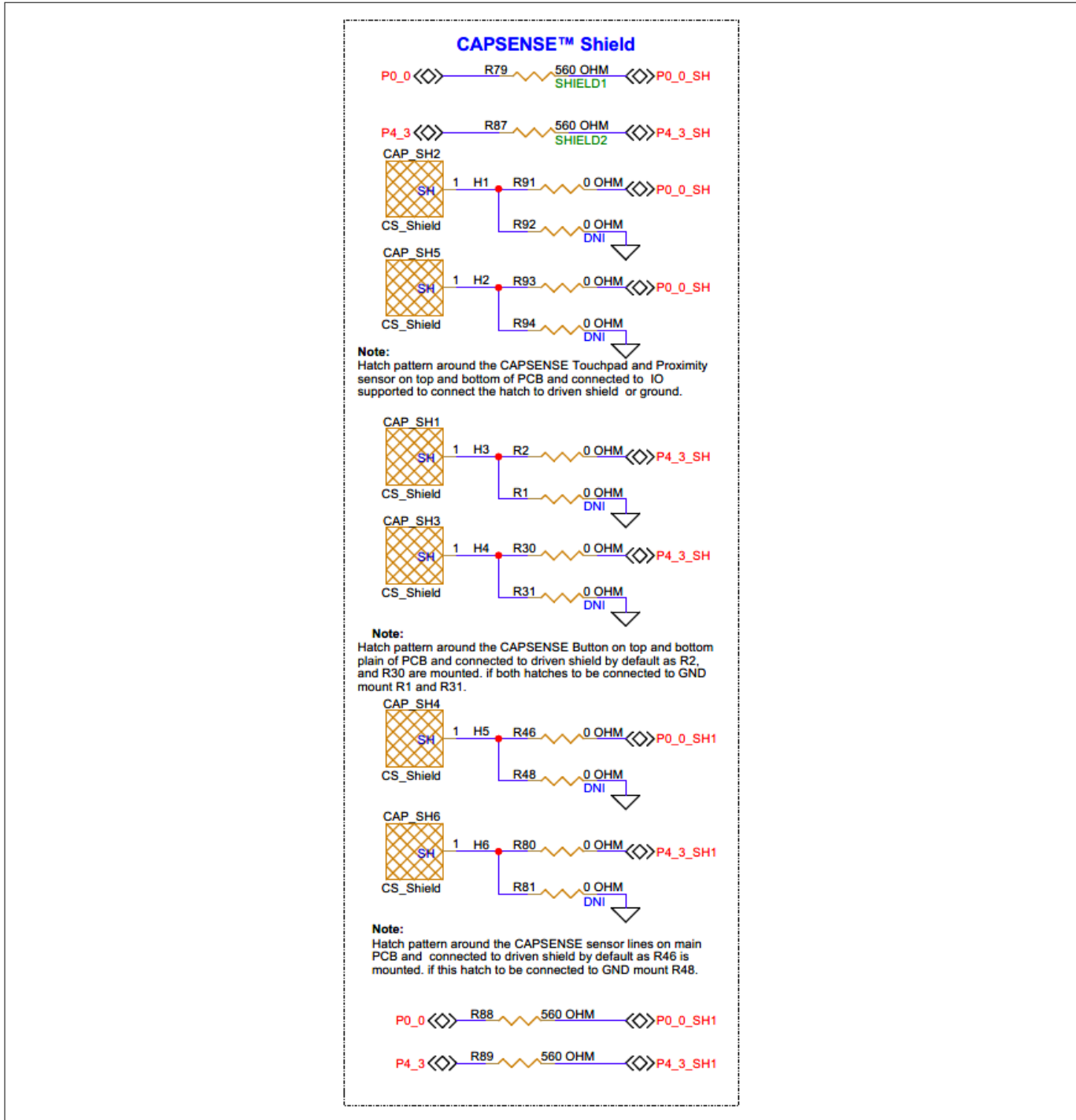

Figure 40 Schematic of driven shield configurations

For detailed information on using CAPSENSE™, including design guidelines, see the [PSOC™ 4 and PSOC™ 6 MCU CAPSENSE™ design guide](#).

3.2.5 Ambient light sensor

The kit includes an ambient light sensor (ALS - Q2) that uses GPIO P2[7] of the PSOC™ 4100T Plus SAR ADC for ambient light sensing.

3 Hardware

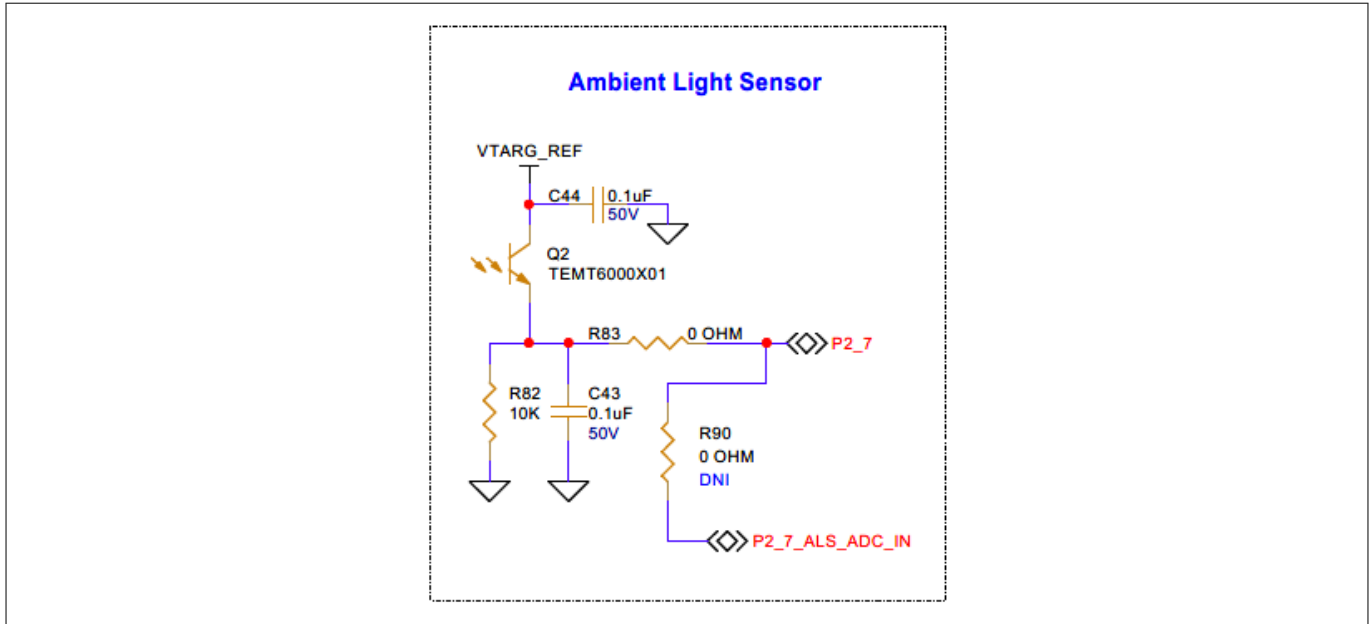

Figure 41 Ambient light sensor schematic

3.2.6 Crystal

A 32.768 kHz crystal footprint is provided onboard and connected to P0[2] and P0[3] of the PSOC™ 4100T Plus MCU to enable the watch crystal oscillator (WCO). By default, these pins are connected to the I/O header (J18). Remove these connections before using the crystal. See [Enabling the WCO for the PSOC™ 4100T Plus device](#) for rework instructions.

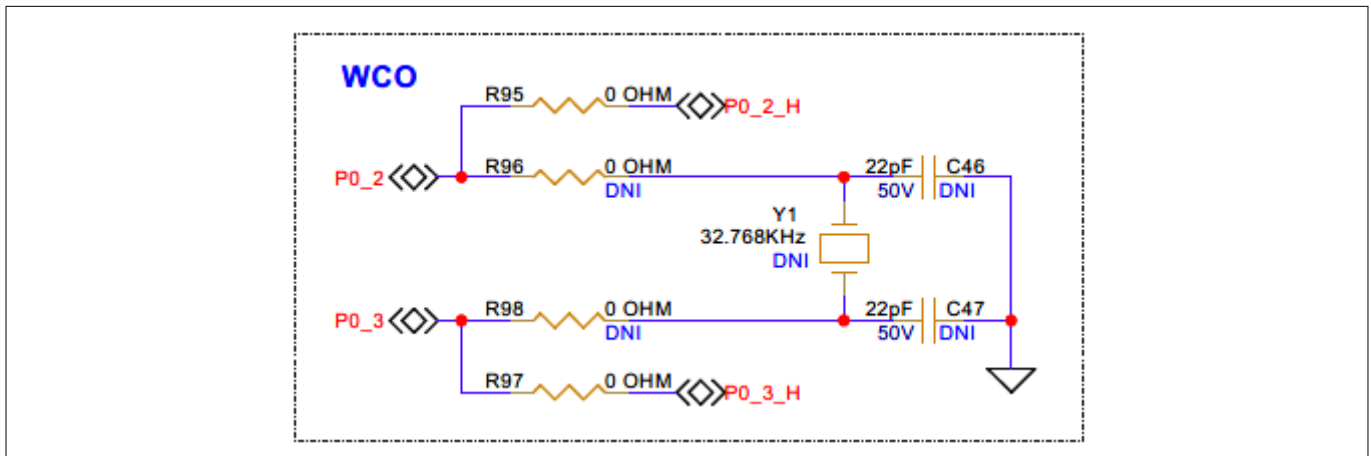

Figure 42 WCO crystal oscillator schematic

3.2.7 User LEDs

The PSOC™ 4100T Plus CAPSENSE™ Prototyping Board includes four user LEDs: LED2, LED3, LED5, and LED6. These LEDs are driven by Q1 and Q3 MOSFETs to isolate the LED current from the PSOC™ 4100T Plus device current (although GPIO peripheral current consumption will still be part of the PSOC™ 4100T Plus device current). By default, the LEDs are powered by the KP\_VBUS USB power input. Additionally, there is a provision on the board to drive the LEDs from the VTARG\_REF power rail.

3 Hardware

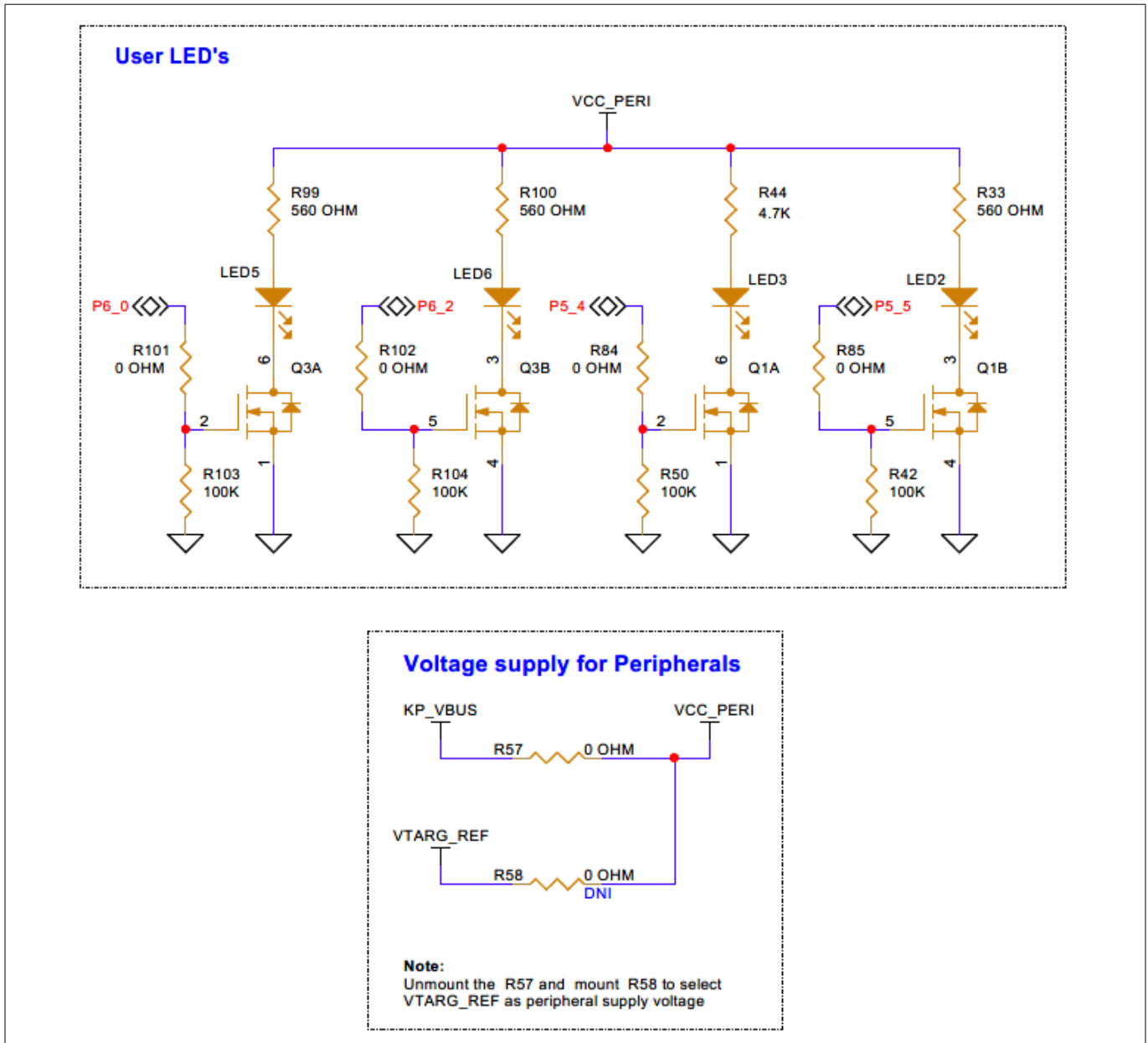

Figure 43 User LEDs schematic

3.2.8 User button

The PSOC™ 4100T Plus CAPSENSE™ Prototyping Board includes a user button, SW4, connected to pin P5[6] of the PSOC™ 4100T Plus device via a resistor, R86. Additionally, a 1K Ω current-limiting resistor, R60, is placed in series to prevent excessive current flow when the I/O is configured as an output and SW4 is pressed.

3 Hardware

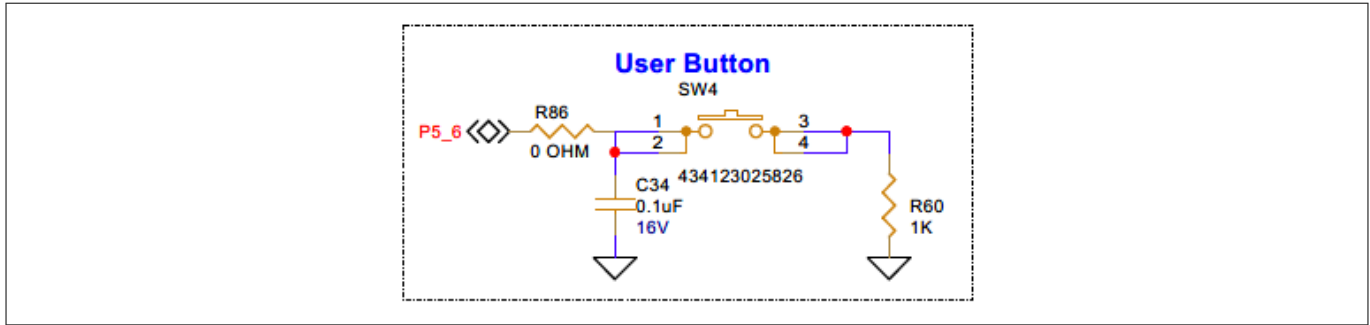

Figure 44 User button schematic

3.2.9 Expansion headers

3.2.9.1 Multi-Sense expansion connector

The PSOC™ 4100T Plus CAPSENSE™ Prototyping Kit includes a 24-pin sensor interface header (J24), offering a convenient and flexible way to connect various sensors and interfaces.

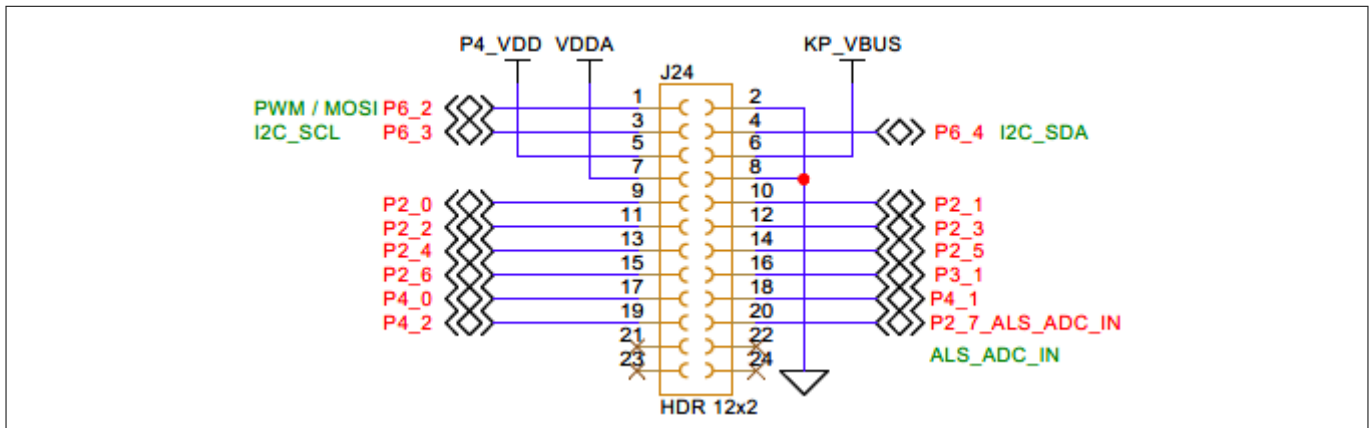

Figure 45 Multi-Sense expansion connector schematic

This header is divided into three main sections:

- Power supply
- Digital interface
- Sensor interface

3.2.9.1.1 Power supply

The power supply section of the header provides power for the sensor expansion board. These pins can be used to power sensors, interfaces, and other devices on the expansion board.

Table 5 Pin assignment of power supply domains

Pin number	Power supply domain	Description
J24.5	P4_VDD	Used for I/O reference only; do not use for powering devices on sensor expansion boards.
J24.6	KP_VBUS (5 V)	Can be used to power devices on the sensor expansion boards.

(table continues...)

3 Hardware

**Table 5** (continued) Pin assignment of power supply domains

Pin number	Power supply domain	Description
J24.7	VDDA	Used for analog reference only; do not use for powering devices on sensor expansion boards.
J24.2, J24.8	GND	Ground

**3.2.9.1.2 Digital interface**

The digital interface section of the header provides digital communication pins for devices on the sensor expansion boards. These pins allow for the transmission of digital signals between the MCU and the connected devices.

**Table 6** Pin assignment of digital interface signals

Pin number	MCU pin number	Primary digital interface	Secondary digital interface
J24.1	P6[2]	GPIO and PWM supported digital output	SPI MOSI interface
J24.3	P6[3]	I <sup>2</sup> C Clock signal	-
J24.3	P6[4]	I <sup>2</sup> C Data signal	-

**3.2.9.1.3 Sensor interface**

The sensor interface section of the header provides signal pins from the PSOC™ 4100T Plus device for connecting sensors and interfaces. These pins can be used to connect capacitive touch sensors and other sensors with analog output. The built-in ADC of the PSOC™ 4100T Plus device can be used to measure the analog signal levels from these sensors.

**Table 7** Pin assignment of sensor interface signals

Pin number	MCU Pin number	Primary sensor interface
J24.9 to J24.15, J24.20	P2[0] - P2[6], P2[7]	Connected to an external sensor interface expansion header (J24), which can be used as: <ul style="list-style-type: none"> <li>• General-purpose I/O</li> <li>• CAPSENSE™ I/O</li> <li>• SAR ADC input</li> </ul>
J24.16	P3[1]	Connected to an external sensor interface expansion header (J24), which can be used as: <ul style="list-style-type: none"> <li>• General-purpose I/O</li> <li>• CAPSENSE™ I/O</li> </ul>
J24.17	P4[0]	Connected to an external sensor interface expansion header (J24), which can be used as: <ul style="list-style-type: none"> <li>• General-purpose I/O</li> <li>• CAPSENSE™ I/O</li> </ul>

(table continues...)

**Table 7** (continued) Pin assignment of sensor interface signals

Pin number	MCU Pin number	Primary sensor interface
J24.18	P4[1]	Connected to an external sensor interface expansion header (J24), which can be used as: <ul style="list-style-type: none"> <li>• General-purpose I/O</li> <li>• CAPSENSE™ I/O</li> </ul>
J24.19	P4[2]	Connected to an external sensor interface expansion header (J24), which can be used as: <ul style="list-style-type: none"> <li>• General-purpose I/O</li> <li>• CAPSENSE™ I/O</li> </ul>

### 3.2.9.2 I/O expansion headers

The PSOC™ 4100T Plus CAPSENSE™ Prototyping Kit includes four headers - J18, J21, J22, and J23, that provide connectivity to the PSOC™ 4100T Plus device GPIOs.

3 Hardware

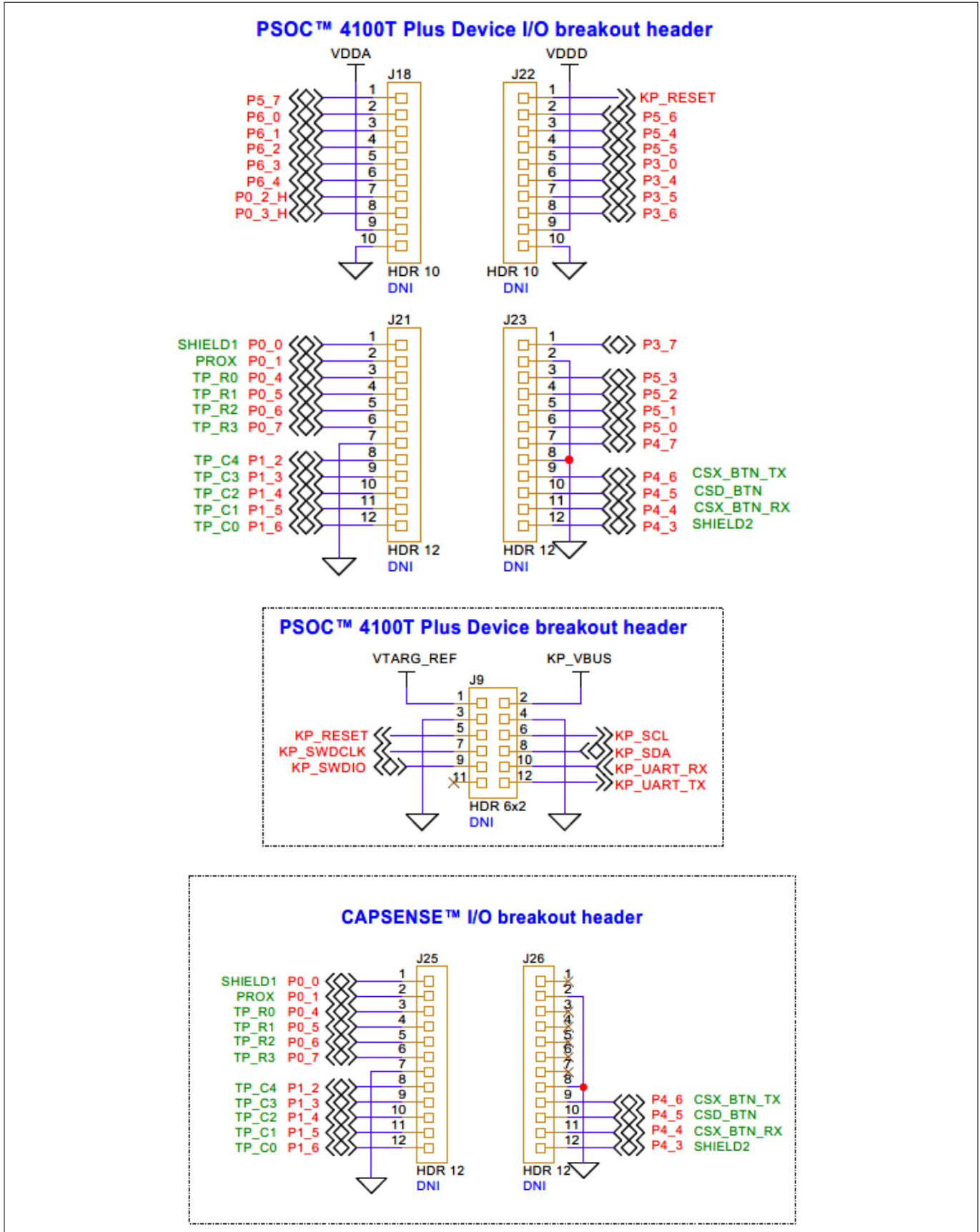

Figure 46 Schematic of expansion headers

3 Hardware

3.3 CY8CPROTO-041TP kit rework for evaluating additional features

3.3.1 Enabling the external programming/debugging interface to the PSOC™ 4100T Plus device

The default programming/debugging interface for the PSOC™ 4100T Plus device is the onboard KitProg3. A 10-pin header (J7) is provided on the kit to interface with an external programmer, such as MiniProg4. By populating the J7 header, MiniProg4 can be directly connected to the PSOC™ 4100T Plus device.

The prototyping board includes provisions for ESD and decoupling capacitors on the VTARG power rail. To enable ESD protection, populate D2. To filter noise on the target reference voltage, populate C20.

Table 8 Rework components with reference and manufacturer details

Reference	Description	Manufacturer	Manufacturer part number
J7	CONN, HDR, MALE, DUAL, 10POS, 1.27 mm, GOLD, STR, SMD	Samtec	FTSH-105-01-L-DV-K-P-TR
D2	DIO, TVS, UNIDIR, 5 V, 18.6 V, 174 W, SOD-523	MCC	ESD5V0D5-TP
C20	CAP, CER, 1 uF, 10%, X5R, 10 V, 0402	Yageo	CC0402KRX5R6BB105

Figure 47 shows the reworked schematic sections.

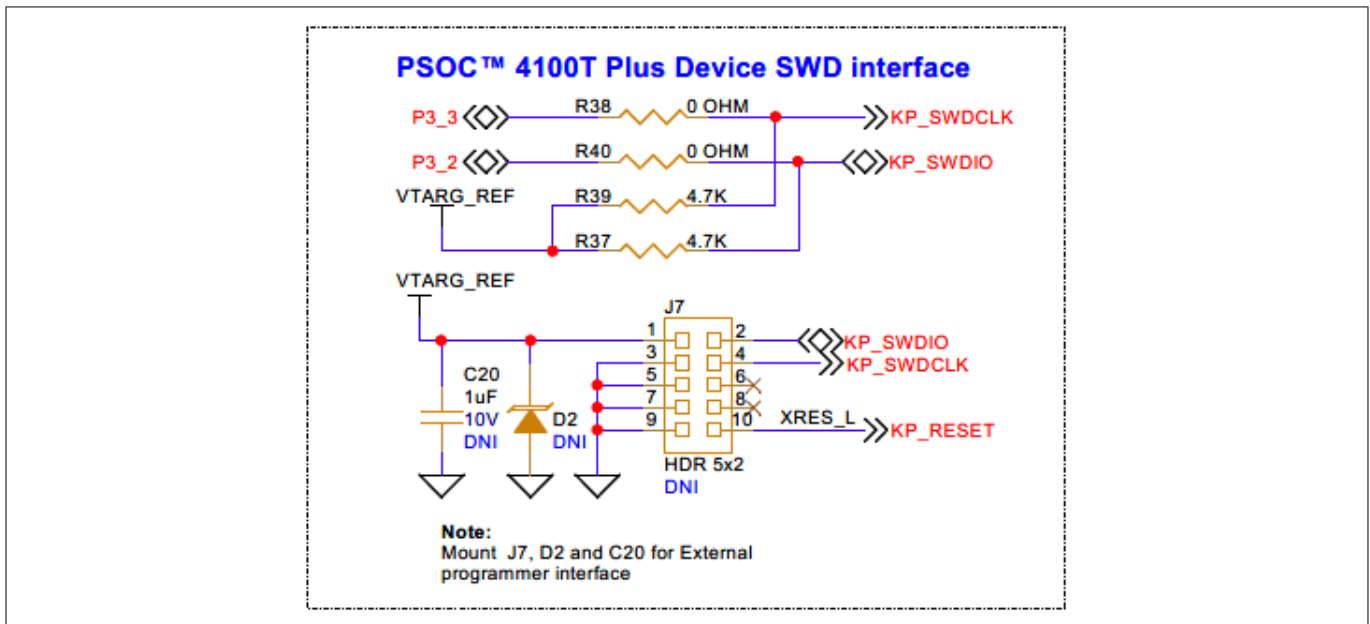

Figure 47 Schematic of rework regions to enable the external programming interface

Table 9 J7 header pin assignment for interfacing with MiniProg4

Pin details	Kit function	MiniProg4 interface function
J7.1	VTAR_REF, PSOC™ 4100T Plus device voltage reference	VTARG, to sense the target MCU voltage
J7.2	P3[2], Port 3 Pin 2, is a GPIO of the PSOC™ 4100T Plus device that supports the SWD interface and is connected to the target MCU via the SWDIO signal.	SWDIO, SWD data in/out interface with the target MCU

(table continues...)

## 3 Hardware

**Table 9 (continued) J7 header pin assignment for interfacing with MiniProg4**

Pin details	Kit function	MiniProg4 interface function
J7.3	GND, ground reference of prototyping board	GND, ground reference of MiniProg4
J7.4	P3[3], Port 3 Pin 3, is a GPIO of the PSOC™ 4100T Plus device that supports the SWD interface and is connected to the target MCU via the SWDCLK signal.	SWDCLK, SWD clock interface with the target MCU
J7.5	GND, ground reference of the prototyping board	GND, ground reference of MiniProg4
J7.6	N.C.	N.C.
J7.7	GND, ground reference of the prototyping board	GND, ground reference of MiniProg4
J7.8	N.C.	N.C.
J7.9	GND, ground reference of the prototyping board	GND, ground reference of MiniProg4
J7.10	XRES_L, reset signal for the PSOC™ 4100T Plus device	XRES, reset signal for the target MCU

The pin assignments for J8 and J9 support the 5-pin programming interface of MiniProg4. Populate a 5-pin header on either J8 or J9 (manufacturer part number PRPC005SAAN-RC or an equivalent can be used), as shown in [Figure 48](#).

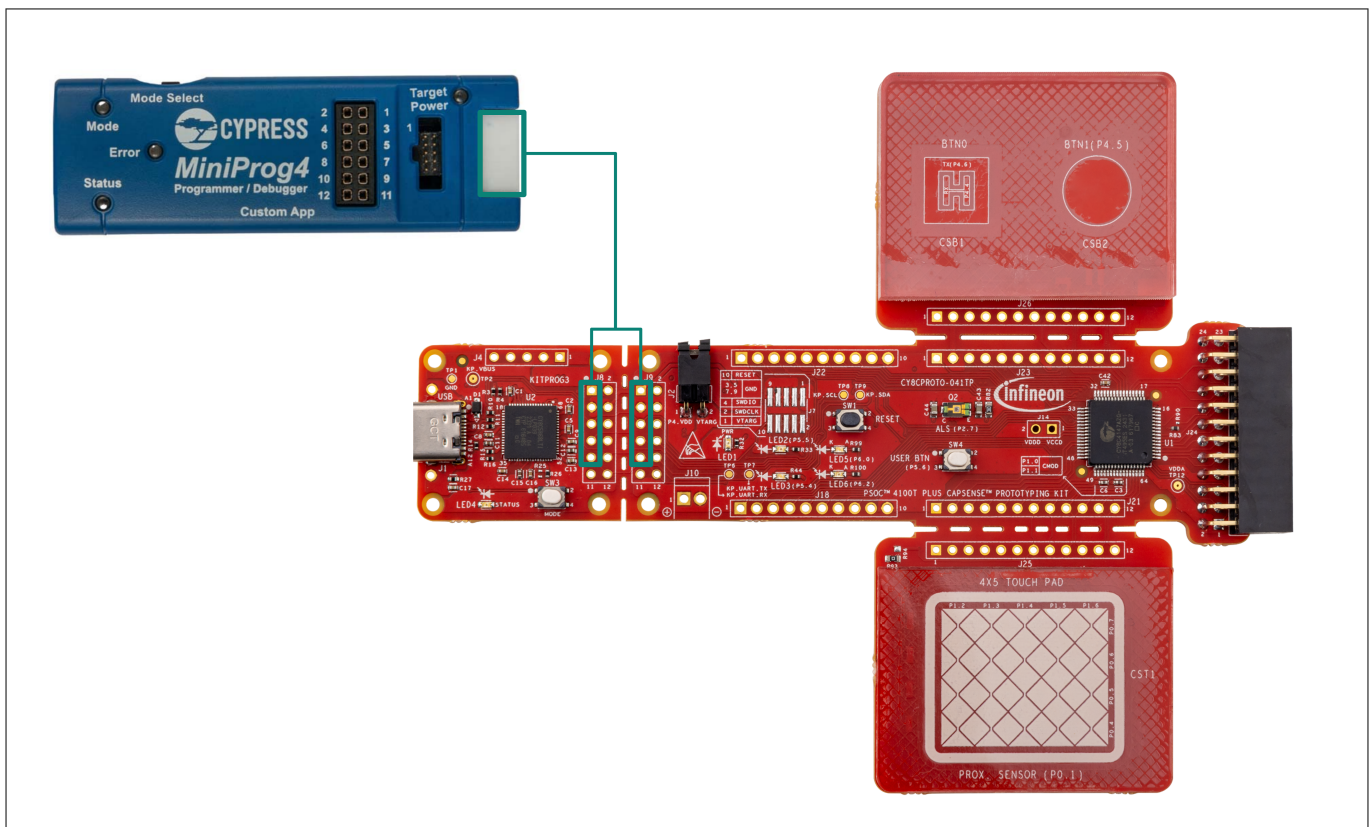

**Figure 48 Rework regions to enable the 5-pin programming interface with MiniProg4**

3 Hardware

**Table 10** Connection details for 5-pin programming interface between MiniProg4 and the kit

5-pin programming interface on MiniProg4	5-pin programming interface on the kit
VTARG	J8.1 or J9.1
GND	J8.3 or J9.3
XRES	J8.5 or J9.5
SWCLK	J8.7 or J9.7
SWDIO	J8.9 or J9.9

**3.3.2 Enabling the external power input for PSOC™ 4100T Plus device**

A 2-pin screw terminal header (J10) provision is provided on the prototyping board to interface an external power supply input for powering the PSOC™ 4100T Plus device. To use this feature, populate the J10 header, remove R52 and populate R53 resistor.

**Table 11** Rework components with reference and manufacturer details

Reference	Description	Manufacturer	Manufacturer part number
J10	CONN, TERMINAL BLOCK, 2.54MM, 2POS, 6A, STR, TH	On Shore Technology, Inc.	OSTVN02A150
R53	RES, Fixed, 0 OHM, JUMPER, 1A, 0603	Yageo	RC0603JR-070RL

Figure 49 shows the reworked schematic section.

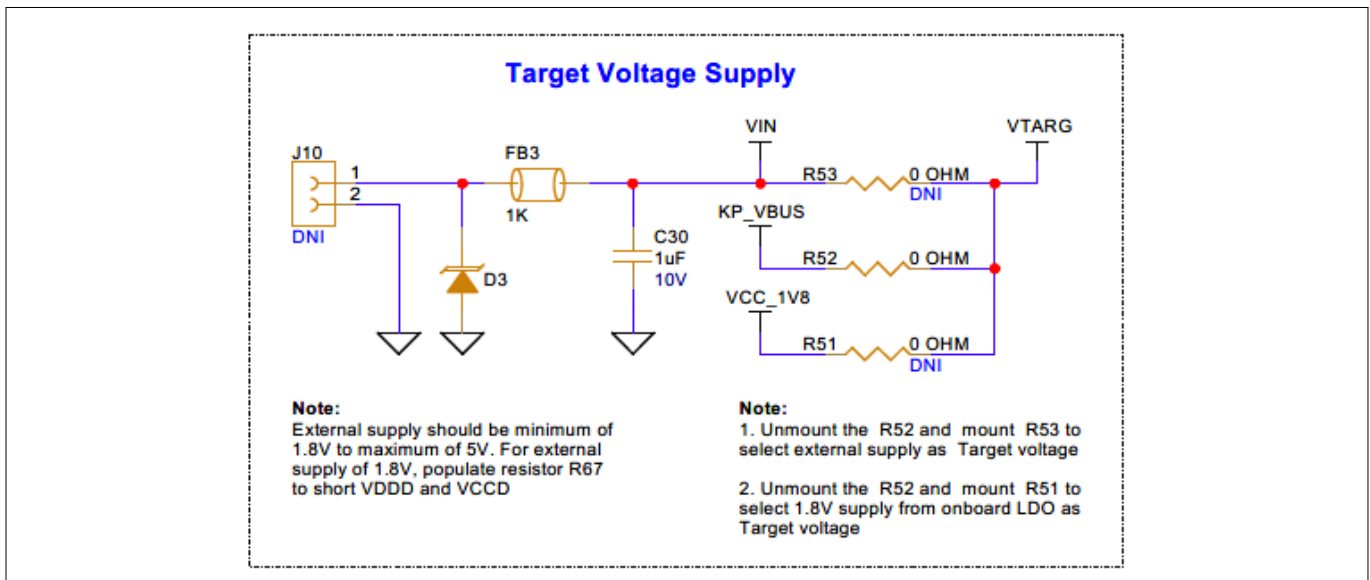

**Figure 49** Schematic of rework regions to enable the external power input for the PSOC™ 4100T Plus device

**3.3.3 Enabling 1.8 V supply for the PSOC™ 4100T Plus device**

By default, the PSOC™ 4100T Plus device is powered by a 5 V supply from a USB Type-C connector. The board also includes a linear voltage regulator provision at U4, which provides a regulated 1.8 V supply to the PSOC™ 4100T Plus device, derived from the 5 V supply from the USB Type-C connector.

## 3 Hardware

**Table 12** Rework components with reference and manufacturer details

Reference	Description	Manufacturer	Manufacturer part number
U4	IC, REG, LDO, 1CH, Fixed, 1.8 V, 0.25 A, 2.2 V to 5.5 V, TSOP-5	Onsemi	NCV8163ASN180T1G
C19, C48	CAP, CER, 1 µF, 10%, X5R, 10 V, 0402	Yageo	CC0402KRX5R6BB105
C18	CAP, CER, 0.1 µF, 10%, X5R, 16 V, 0402	Walsin Technology	0402X104K160CT
R41	RES, Fixed, 100K, 5%, 1/16 W, 0402	Yageo	RC0402JR-07100KL

Populate the components mentioned in [Table 12](#). Remove R52 and populate R51. [Figure 50](#) shows the reworked schematic sections.

**Note:** *Populate R67 to short VCCD and VDDD when the PSOC™ 4100T Plus device is powered by a 1.8 V supply.*

3 Hardware

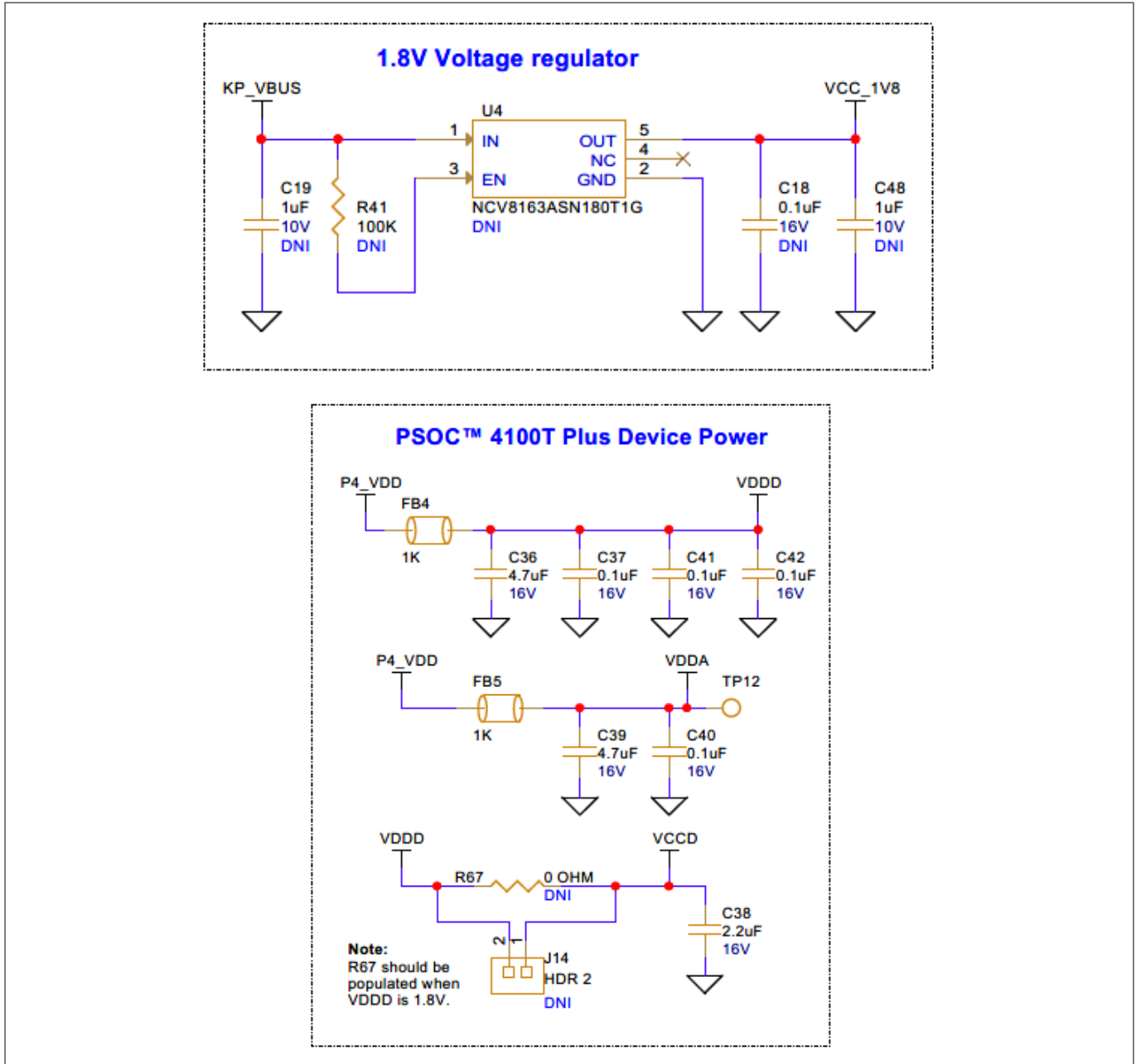

Figure 50 Schematic of rework regions to enable 1.8 V powering option for the PSOC™ 4100T Plus device

3.3.4 Enabling the WCO for the PSOC™ 4100T Plus device

By default, the watch crystal oscillator (WCO) is not populated on the PSOC™ 4100T Plus CAPSENSE™ Prototyping Board. To enable the WCO, populate the crystal (Y1) and load capacitors C46 and C47. Additionally, remove resistor R95, R97 and populate resistors R96, R98 to connect the crystal (Y1) to the PSOC™ 4100T Plus device.

3 Hardware

**Table 13 Rework components with reference and manufacturer details**

Reference	Description	Manufacturer	Manufacturer part number
Y1	XTAL, 32.768 kHz, 20 ppm, 12.5 pF, SMD	Würth Elektronik	830065253
C46, C47	CAP, CER, 22 pF, 5%, NP0, 50 V, 0402	Würth Elektronik	885012005057
R96, R98	RES, Fixed, 0 OHM, JUMPER, 0.63 A, 0402	Panasonic	ERJ-2GE0R00X

Figure 51 shows the reworked schematic sections.

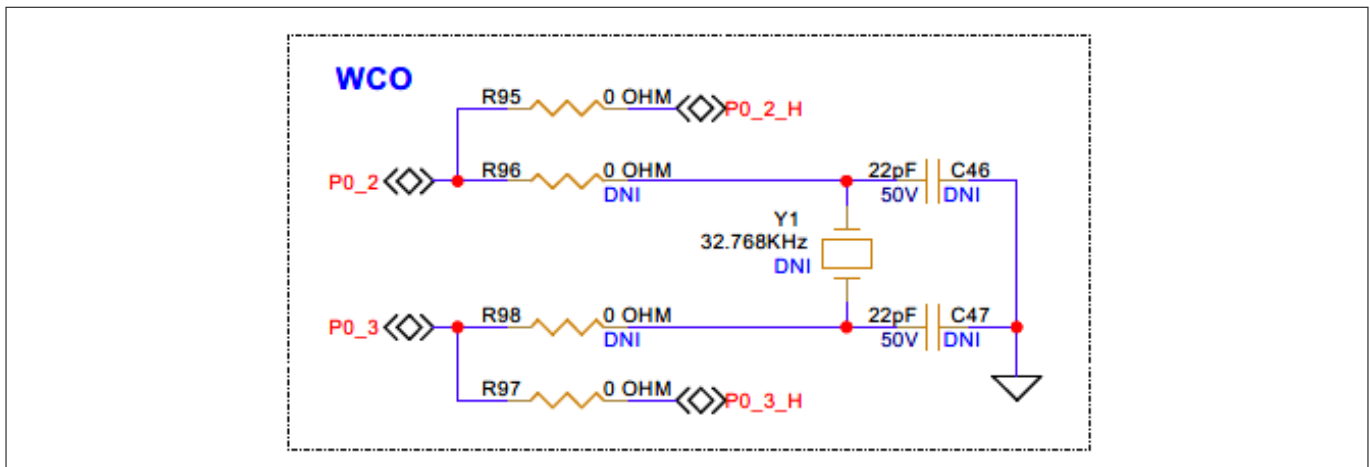

**Figure 51 Schematic of rework regions to enable the WCO for the PSOC™ 4100T Plus device**

### 3.3.5 Enabling additional sense signal for Multi-Sense expansion connector

By default, pin P2[7] of the PSOC™ 4100T Plus device is connected to the ambient light sensor (Q2). A provision is provided to use this pin for the sensor interface header. To establish the signal connection with the sensor expansion header (J24), populate R90 and remove R83.

**Table 14 Rework components with reference and manufacturer details**

Reference	Description	Manufacturer	Manufacturer part number
R90	RES, Fixed, 0 OHM, JUMPER, 1A, 0402	Yageo	RC0402JR-070RL

Figure 52 shows the reworked schematic sections.

3 Hardware

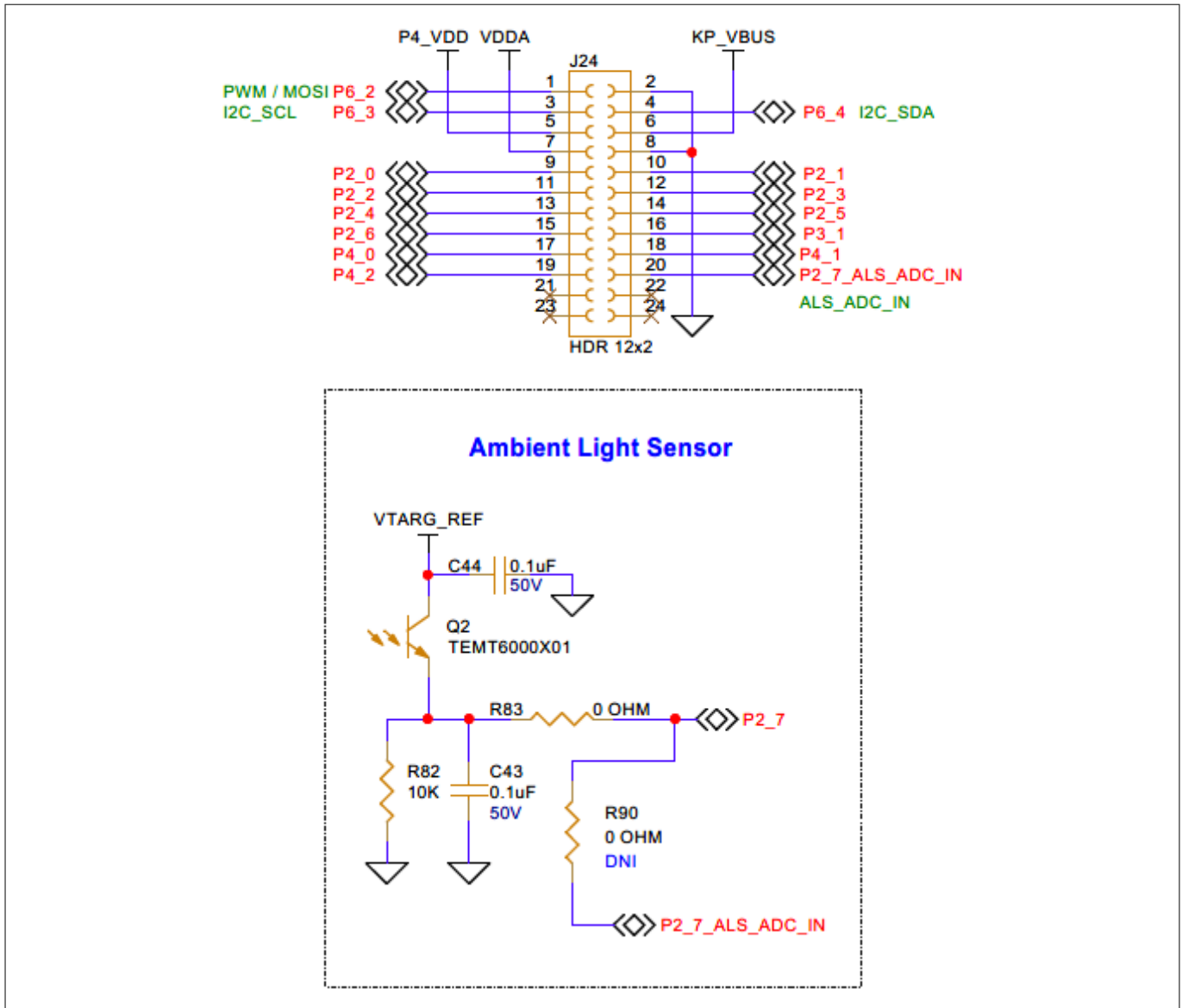

Figure 52 Schematic of rework regions to enable additional sense signal for Multi-Sense expansion connector

3.4 Bill of materials

See the BOM files available on the [kit webpage](#).

## Glossary

**ADC**

Analog-to-digital converter

**BOM**

Bill of materials

**BSP**

Board support package

**CLI**

Command-line interface

**CMOD**

Modulator capacitor

**CMSIS-DAP**

Cortex® Microcontroller System Interface Standard – Debug Access Port

**CPU**

Central processing unit

**CSD**

Self-capacitance

**CSX**

Mutual-capacitance

**EMC**

Electromagnetic compatibility

**ESD**

Electrostatic discharge

**GND**

Ground

**GPIO**

General-purpose input/output

**HMI**

Human-machine interface

**I2C**

Inter-integrated circuit

**IDE**

Integrated development environment

**LED**

Light emitting diode

## Glossary

**MCU**

Microcontroller unit

**MSC**

Multi-sense converter

**OOB**

Out-of-the-box

**PSOC™**

Programmable system-on-chip

**SAR**

Successive Approximation Register

**SCL**

Serial clock (I<sup>2</sup>C)

**SDA**

Serial data (I<sup>2</sup>C)

**SWD**

Serial Wire Debug

**UART**

Universal Asynchronous Receiver-Transmitter

**USB**

Universal Serial Bus

**XRES**

External reset

## Revision history

---

### Revision history

Document revision	Date	Description of changes
**	2024-09-20	Initial release
*A	2025-03-28	Updated the following sections: <a href="#">Hardware</a> section with Rev03 board details <a href="#">Using the OOB example CE240380</a>

### Trademarks

PSoC™, formerly known as PSoC™, is a trademark of Infineon Technologies. Any references to PSoC™ in this document or others shall be deemed to refer to PSoC™.

#### **Trademarks**

All referenced product or service names and trademarks are the property of their respective owners.

**Edition 2025-03-28**

**Published by**

**Infineon Technologies AG**

**81726 Munich, Germany**

**© 2025 Infineon Technologies AG**

**All Rights Reserved.**

**Do you have a question about any aspect of this document?**

**Email: [erratum@infineon.com](mailto:erratum@infineon.com)**

**Document reference**

**IFX-clr1721106007074**

For further information on the product, technology, delivery terms and conditions and prices please contact your nearest Infineon Technologies office ([www.infineon.com](http://www.infineon.com))

#### **Warnings**

Due to technical requirements products may contain dangerous substances. For information on the types in question please contact your nearest Infineon Technologies office.

Except as otherwise explicitly approved by Infineon Technologies in a written document signed by authorized representatives of Infineon Technologies, Infineon Technologies' products may not be used in any applications where a failure of the product or any consequences of the use thereof can reasonably be expected to result in personal injury.